

# SR-1010 SERIES

## Resistance Transfer Standards

### User and Service Manual

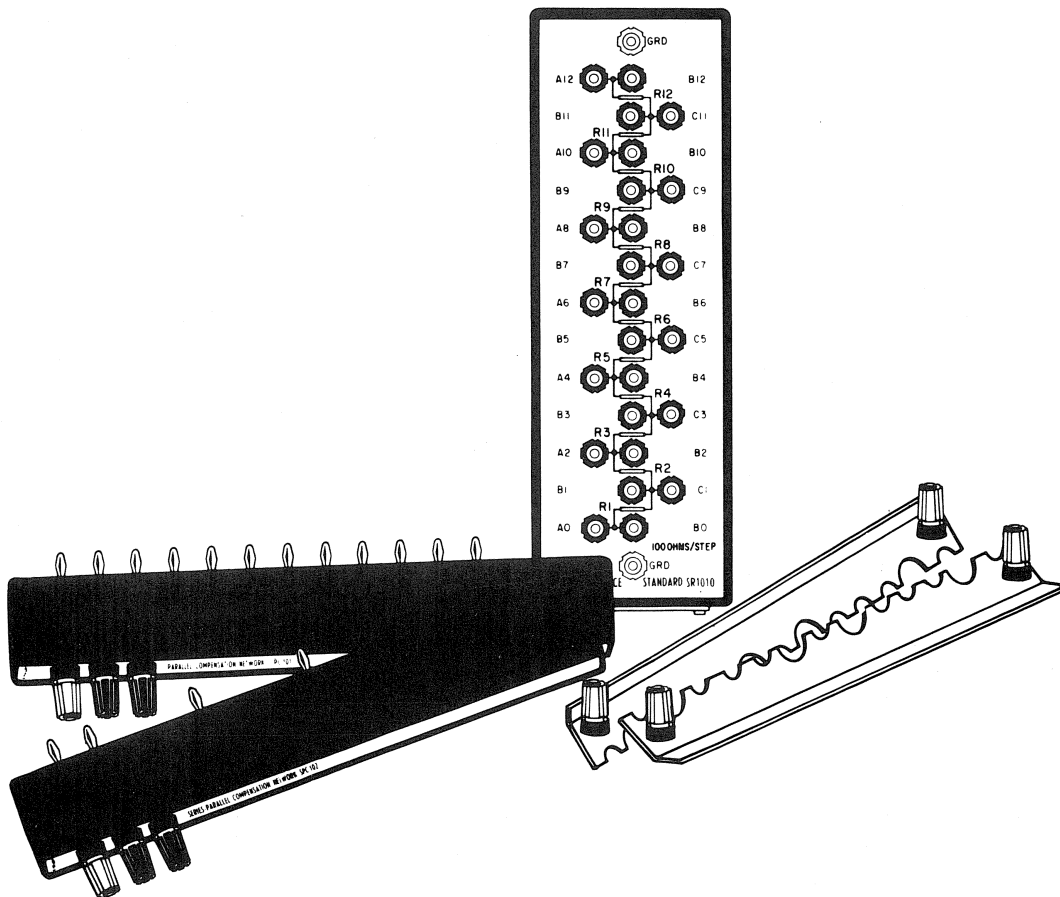

Copyright © 2008 IET Labs, Inc.

SR-1010 im/November, 2008



**IET LABS, INC.**  
formerly manufactured by  
**esi/Tegam**

534 Main Street, Westbury, NY 11590 [www.ietlabs.com](http://www.ietlabs.com)  
TEL: (516) 334-5959 • (800) 899-8438 • FAX: (516) 334-5988

◆ PRECISION INSTRUMENTS FOR TEST AND MEASUREMENT ◆



**IET LABS, INC.**

534 Main Street, Westbury, NY 11590

[www.ietlabs.com](http://www.ietlabs.com)

TEL: (516) 334-5959 • (800) 899-8438 • FAX: (516) 334-5988

## **WARRANTY**

We warrant that this product is free from defects in material and workmanship and, when properly used, will perform in accordance with applicable IET specifications. If within one year after original shipment, it is found not to meet this standard, it will be repaired or, at the option of IET, replaced at no charge when returned to IET. Changes in this product not approved by IET or application of voltages or currents greater than those allowed by the specifications shall void this warranty. IET shall not be liable for any indirect, special, or consequential damages, even if notice has been given to the possibility of such damages.

THIS WARRANTY IS IN LIEU OF ALL OTHER WARRANTIES, EXPRESSED OR IMPLIED, INCLUDING BUT NOT LIMITED TO, ANY IMPLIED WARRANTY OF MERCHANTABILITY OR FITNESS FOR ANY PARTICULAR PURPOSE.



## WARNING



OBSERVE ALL SAFETY RULES  
WHEN WORKING WITH HIGH VOLTAGES OR LINE VOLTAGES.

**Dangerous voltages may be present inside this instrument. Do not open the case  
Refer servicing to qualified personnel**

### **HIGH VOLTAGES MAY BE PRESENT AT THE TERMINALS OF THIS INSTRUMENT**

WHENEVER HAZARDOUS VOLTAGES (> 45 V) ARE USED, TAKE ALL MEASURES TO  
AVOID ACCIDENTAL CONTACT WITH ANY LIVE COMPONENTS.

USE MAXIMUM INSULATION AND MINIMIZE THE USE OF BARE  
CONDUCTORS WHEN USING THIS INSTRUMENT.

**Use extreme caution when working with bare conductors or bus bars.**

WHEN WORKING WITH HIGH VOLTAGES, POST WARNING SIGNS AND  
KEEP UNREQUIRED PERSONNEL SAFELY AWAY.



## CAUTION



DO NOT APPLY ANY VOLTAGES OR CURRENTS TO THE TERMINALS OF THIS  
INSTRUMENT IN EXCESS OF THE MAXIMUM LIMITS INDICATED ON  
THE FRONT PANEL OR THE OPERATING GUIDE LABEL.

## TABLE OF CONTENTS

I.	INTRODUCTION	
1.1	DESCRIPTION	1-1
1.2	SPECIFICATIONS	1-3
1.2.1	Models SR 1010, SR 1010/LTC	1-3
1.2.2	Model SR 1010/MT	1-4
1.2.3	Model SB 103 Shorting Bar	1-5
1.2.4	Model PC 101 Parallel Compensation Network	1-5
1.2.5	Model SPC 102 Series-Parallel Compensation Network	1-5
II.	OPERATING INSTRUCTIONS	
2.1	BASIC OPERATIONS	2-1
2.1.1	Using the Calibration Chart	2-1
2.1.2	High-Accuracy Traceable Resistance Measurements	2-2
2.1.3	Divider Calibration	2-2
2.2	CONNECTIONS	2-4
2.2.1	Single Resistor Or Series Group	2-4
2.2.2	Parallel Group Of Resistors	2-5
2.2.3	Series-Parallel Group Of Resistors	2-7
2.2.4	Divider Connections	2-8
2.3	HIGH ACCURACY CALIBRATION TRANSFER	2-10
2.3.1	Introduction	2-10
2.3.2	Making Equal Resistance Comparisons	2-10
2.3.3	Primary Resistance Standards	2-11
2.3.4	Calibration Transfer Between SR 1010 Transfer Standards	2-12
2.3.5	Calibration Transfer Between Principal Configurations	2-13
2.3.6	Calibration Transfer To Individual Resistors	2-14
2.3.7	Calibration Of An SR 1010 As A Ten-Step Divider	2-14
2.4	CALIBRATION OF INDIVIDUAL RESISTORS	2-16
III.	THEORY	
3.1	JUNCTION RESISTANCE EFFECTS	3-1
3.2	INSULATION RESISTANCE EFFECTS	3-2
3.3	BASIC TRANSFER ACCURACY	3-3
3.4	FOUR-TERMINAL PARALLELING	3-4
3.5	LINEARITY DEVIATION	3-7
IV.	APPLICATIONS	
4.1	RESISTANCE TRANSFER WITH MODEL 123 RESISTANCE COMPARISON SYSTEM	4-1
4.1.1	System Description	4-1
4.1.2	Transfer From 10 Kilohms To 100 Kilohms and 1 Kilohm	4-3
4.1.3	Transfer From 10 Kilohms To 100 Ohms	4-4
4.1.4	Transfer From 10 Kilohms To 10 Ohms	4-4
4.1.5	Transfer From 10 Kilohms To 1 Ohm	4-5
4.2	DETAILED TRANSFER TECHNIQUE WITH MODEL 242B RESISTANCE MEASUREMENT SYSTEM	4-7
4.2.1	System Description	4-7
4.2.2	Equipment Required	4-7
4.2.3	Detailed Procedure	4-8
V.	PARTS LIST	5-1



# SECTION I

## INTRODUCTION

### 1.1 DESCRIPTION

Each Model SR 1010 Resistance Transfer Standard is a resistance box containing twelve nominally equal precision resistors. SR 1010 boxes are available in various resistance values.

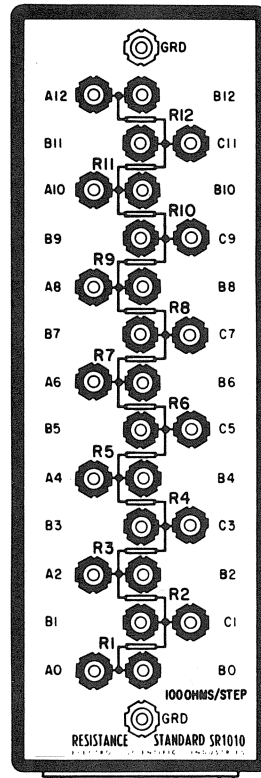

Figure 1-1.

There are three basic ways of using a Model SR 1010, depending upon the accuracy required. In many applications, the resistor adjustment accuracy is high enough that the resistors can be assumed to have exactly their nominal values. For higher accuracy, certified calibration data can be used to correct the resistance values. For the ultimate accuracy in a laboratory having a high-accuracy reference standard, a set of SR 1010 boxes can be used to transfer calibration from the reference to the entire chain of resistance measuring equipment and standards in the laboratory with an accuracy at the time of calibration much better than the long-term accuracy to which any of the equipment could be certified.

Each Model SR 1010 Resistance Transfer Standard has a calibration chart attached to it, giving the measured deviation of each resistor from its nominal value. The chart also includes the calculated average deviations of resistor groups for use in series, parallel and series-parallel groups. The ESI calibration data supplied is directly traceable to standards certified by the National Bureau of Standards. Blank calibration charts are available for subsequent calibrations. The excellent stability and unusually low temperature coefficient of the resistors used in the SR 1010 assure the maintenance of high accuracy between calibration periods and over normal temperature ranges.

The design of the Model SR 1010 Resistance Transfer Standard and its accessories facilitates the transfer of resistance calibration from one resistance level to another. The series, parallel and series-parallel connections of resistor groups in an SR 1010 to give resistance values of 0.1, 1 and 10 times the individual resistor value is particularly useful in calibrating a set of SR 1010s to a short-term accuracy much better than any long-term certification.

The resistors in an SR 1010 are permanently connected in series. The provision of two binding post terminals at each junction allows accurate four-terminal measurement of any resistor or series group of resistors. Accessories are available for parallel and series-parallel connections. A pair of shorting bars, ESI Model SB 103 is used to connect any number of resistors in parallel or a group of nine resistors in series-parallel. Two different compensation networks, ESI Models PC 101 and SPC 102, are used to eliminate loss of accuracy at the lower resistance levels in making four-terminal measurements of ten resistors in parallel and nine resistors in series-parallel. As a result of the special design of the four-terminal junctions between binding posts and resistors, and the use of the parallel and series-parallel compensation networks, the actual values of four-terminal series, parallel and series-parallel resistor groups will agree with their values calculated from individual resistor values to better than  $\pm 0.1$  microhm.

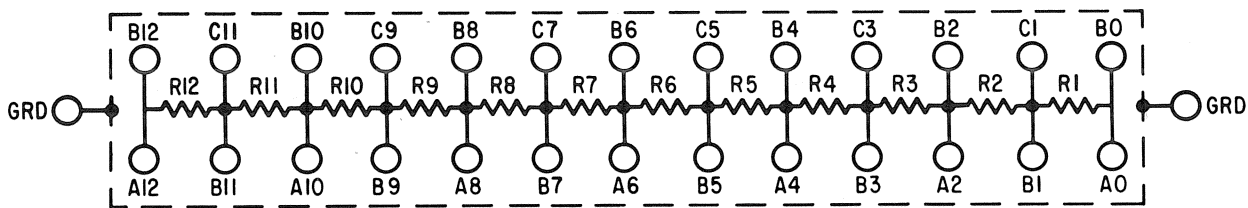

Figure 1-2.

The SR 1010 owes its high accuracy and stability to the precision resistors used. The resistors are unifilar-wound on specially processed mica cards, and use a modern alloy resistance wire which has excellent stability, extremely low temperature coefficient and negligible thermal emf to copper. All the resistors in an SR 1010 are wound from the same spool of wire in order to yield the best temperature coefficient and stability matching between resistors. Each resistor is carefully built and inspected to insure maximum control of quality. Resistors for use in Model SR 1010's are selected for minimum temperature coefficient and given a rigorous accelerated aging treatment. The complete resistance transfer standard is given additional stabilization treatment, followed by an extended series of tests to ensure that every SR 1010 conforms to the highest standards of quality.



## 1.2 SPECIFICATIONS

### 1.2.1 Model SR 1010, SR 1010/LTC

Resistance Values: Twelve equal four-terminal resistors connected in series. Standard Values: 1 or 100 ohms; 1, 10, or 100 kilohms per step. Values required for 242A system calibration: 10 ohms, 1 kilohm, 100 kilohms. Model SR 1010LTC available in 10 ohms per step.

Calibration Transfer Accuracy With Paralleling Compensation Network:

100 to 1 transfer  
 $\pm(1 \text{ ppm} + 0.1 \text{ microhm at parallel value})$ .  
 10 to 1 transfer  
 $\pm(1 \text{ ppm} + 1 \text{ microhm at series-parallel value})$ .

Initial Calibration Chart Accuracy:  $\pm 10 \text{ ppm}$  (traceable to National Bureau of Standards).

Initial Adjustment Accuracy of Resistors:  $\pm 20 \text{ ppm}$ , matched within 10 ppm.

Long-Term Stability of Resistors: Resistance will remain within  $\pm 50 \text{ ppm}$  of nominal value for more than two years.

Calibration Conditions:  $23^\circ\text{C}$ , four-terminal resistance measurements, negligible power.

Temperature Coefficient of Resistors:

100 ohms and higher,  $\pm 5 \text{ ppm}/^\circ\text{C}$ , matched within  $3 \text{ ppm}/^\circ\text{C}$ .  
 1 ohm,  $\pm 15 \text{ ppm}/^\circ\text{C}$ , matched within  $5 \text{ ppm}/^\circ\text{C}$   
 SR 1010/LTC (10 ohms)  $\pm 1 \text{ ppm}/^\circ\text{C}$ .

Power Coefficient of Resistors for Typical Measurement Duty Cycle:

100 ohms and higher,  $\pm 0.1 \text{ ppm}/\text{mW}/\text{resistor}$ .  
 1 Ohm,  $\pm 0.3 \text{ ppm}/\text{mW}/\text{resistor}$ .  
 SR 1010/LTC (10 ohms)  $\pm 0.02 \text{ ppm}/\text{mW}/\text{resistor}$ .

Power Rating: 1 W per step or 5W distributed over ten resistors.

Breakdown Voltage: 1500 V peak to case.

Standard SR 1010 Values:

(R) Value - Per Step		1 $\Omega$	10 $\Omega$ SR1010/LTC	100 $\Omega$	1k $\Omega$	10k $\Omega$	100k $\Omega$
One Resistor Alone	Maximum Milliampere	1000	320	100	32	10	3.2
	Maximum Volts	1	3.2	10	32	100	320
10 Resistors in Parallel (R/10)	Maximum Milliampere	7100	2300	710	230	71	23
	Maximum Volts	0.71	2.3	7.1	23	71	230
10 Resistors in Series (10R)	Maximum Milliampere	710	230	71	23	7.1	2.3
	Maximum Volts	7.1	23	71	230	710	2300*

\*Do not exceed 1500 peak volts to case

Dimensions: Width 12.2 in. (31 cm), height 4.4 in. (11.2 cm), depth 4 in. (10.15 cm).

Weight: 3.25 lb net (1.5 kg).

### 1.2.2 Model SR 1010/MT

Model SR 1010/MT is a 10-kilohm-per-step transfer standard that is similar to the 10-kilohm-per-step Model SR 1010. It differs in that each resistance step can be trimmed through a 100-part-per-million range. Each resistance step consists of a network that is shown schematically in the following figure:

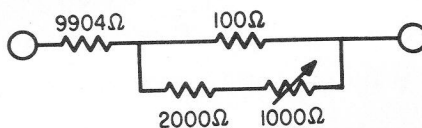

The specifications of the Model SR 1010/MT are as follows:

Standard Value: 10kΩ per step, adjustable.

#### Accuracy

Transfer:  $\pm 0.1$  ppm at 100:1 and 10:1 transfer when used with transfer accessories SB 103, PC 101 and SPC 102.

Initial Drift Rate: Not to exceed 15 ppm/year drift during the first year on each individual resistor, decreasing substantially in succeeding years.

Resolution of Adjustment:  $\pm 0.1$  ppm.

Adjustment Range: Approximately 100 ppm.

Absolute Linearity:  $\pm 0.1$  ppm.

Terminal Linearity: Same as absolute linearity.

#### Temperature Coefficients

Transfer Box Temperature Coefficient:  $\pm 1$  ppm at 23°C. (Rate of change of TC is  $-(0.07 \pm 0.02)$  ppm/°C<sup>2</sup>).

Temperature Coefficient of Linearity:  $\pm 0.5$  ppm/°C of 9 or more steps from the zero end.

Power Coefficient:  $\pm 0.05$  ppm/mW per step.

Maximum Power Rating: 1W/step or 5W distributed over 10 resistors.

Breakdown Voltage: 1500V peak to case.

Leakage Resistance: Greater than  $10^{12}$  ohms from terminal to case.

#### Maximum Ratings:

Number of Resistors	Maximum Current	Maximum Voltage	Maximum Power
One	10 mA	100 V	1 W
10 in Parallel	71 mA	71 V	5 W
10 in Series	7.1 mA	710 V	5 W
9 in Series-Parallel	23 mA	230 V	5 W

### 1.2.3 Model SB 103 Shorting Bars

Function: A pair of shorting bars used to connect any number of resistors of a Model SR 1010 Resistance Transfer Standard in parallel or nine of its resistors in a series-parallel arrangement.

Effective Resistance and Accuracy: See Combined Functional Specifications.

Resistance: End to end: approximately  $100 \mu\Omega$ /bar.

Maximum Current: 10 A/bar.

### 1.2.4 Model PC 101 Parallel Compensation Network

Function: Used in addition to an SB 103 pair for the four-terminal parallel connection of ten resistors in an SR 1010 to yield the same resistance as the value calculated from individual four-terminal resistor measurements.

Effective Resistance and Accuracy: See Combined Functional Specifications.

Resistor Matching: Matched to  $\pm 0.05\%$ .

Maximum Current: 2 A.

Breakdown Voltage: 1500 V to case.

### 1.2.5 Model SPC 102 Series-Parallel Compensation Network

Function: Used in addition to an SB 103 pair for the four-terminal series-parallel connection of nine resistors in an SR 1010, to yield the same resistance as the value calculated from individual four-terminal resistor measurements.

Effective Resistance and Accuracy: See Combined Functional Specifications.

Resistor Matching: Matched to  $\pm 0.05\%$ .

Maximum Current: 2.0 A.

Breakdown Voltage: 1500 V to case.

Combined Functional Specifications:

Resistor Grouping	Ten Resistors in Parallel	Nine Resistors in Series-Parallel	Ten Resistors in Series
Nominal Value (Relative to Individual Resistor Value R)	0.1R	R	10R
Four-Terminal Measurement	Resistance Added to Value Calculated from Individual Resistor Values (Value and Tolerance in Microhms)		
With SB 103 and PC 101 or SPC 102	$0 \pm 0.1$	$0 \pm 1$	
With SB 103 Alone	$50 \pm 10$	$200 \pm 40$	
With no Accessories			$0 \pm 10$
Two-Terminal Measurement			
With SB 103	$150 \pm 30$	$300 \pm 60$	
With no Accessories			$300 \pm 60$



## SECTION II

### OPERATING INSTRUCTIONS

#### 2.1 BASIC OPERATIONS

##### 2.1.1 Using The Calibration Chart

The calibration chart on the end of each SR 1010 gives resistance calibration data for individual resistors and groups of resistors in the SR 1010, in terms of their deviation from nominal value, expressed in parts per million. These values are based on four-terminal measurements; two-terminal measurements must be corrected for the connection resistances listed in the specifications and discussed in Section 2.2 (Connections).

A sample calibration chart is shown in Figure 2-1.

SR1010		OHM/STEP	
ELECTRO SCIENTIFIC INDUSTRIES U.S.A.			
DEVIATION FROM NOMINAL			
		Individual (ppm)	Cumulative (ppm)
INSP	R1	+2	+2
	R2	+4	+3
	R3	-1	+2
	R4	+4	+2
	R5	+5	+3
DATE	R6	-3	+2
	R7	+3	+2
	R8	-5	+1
TEMP	R9	+2	+1
	R10	+5	+2
SER NO.	R11	+4	+2
	R12	+2	+2

MAX POWER  
1 WATT/RESISTOR  
OR 5 WATT TOTAL

TRACEABLE TO  
U.S. NATIONAL BUREAU OF STANDARDS

CONTRACT NO.  
FSN 6625.

Figure 2-1.

The first column gives the measured deviation of each resistor from its nominal value. The second column gives the cumulative average of the deviation figures in the first column, rounded to the same number of significant figures as the first column. For example, to the right of R7, the figure in the first column is the measured deviation of R7 from nominal, while the figure in the second column is the calculated average deviation of resistors R1 through R7.

The cumulative average deviation in the second column calibrates any series, parallel or series-parallel connection of the corresponding group of resistors in which the power divides equally among all the resistors in the group. For example, the first nine resistors in an one ohm per step box can be connected in series for a nominal value of nine ohms, in parallel for one-ninth of an ohm, or in series-parallel for one ohm; the actual value of each of these three alternate connections will be exactly the same number of parts per million away from the nominal value for that connection.

## 2.1.2 High-Accuracy Traceable Resistance Measurements

The calibration of precision resistors must often be traceable through a succession of precise resistance comparisons to a reference standard which has been calibrated by a national standardizing agency (e.g. the National Bureau of Standards). The values most often used for the primary standard are 1 ohm and 10 kilohms. Other standards, working standards, in the laboratory can be calibrated by transferring from 1 ohm or 10 kilohms.

A set of SR1010 Transfer Standards is particularly useful for high-accuracy calibration since the SR1010 is specifically designed for the transfer of calibration of resistance from one level to another. The transfer of calibration is accomplished by calibrating the resistance of the transfer standard with the resistors connected in one configuration, (series, parallel, or series-parallel) and then changing the configuration so that the total resistance is different, but the accuracy is the same.

A Kelvin Bridge or a double ratio set (a direct reading double ratio set for maximum convenience) can be used with a set of Model SR 1010 Transfer Standards to compare resistance standards of various values to the calibrated reference standard. With this equipment, one can obtain greater accuracy for short-term use than could be obtained by shipping the other standards to the national standardizing agency.

Examples of transferring from a 10 kilohm primary standard to resistance levels from 1 megohm to 1 ohm are given in section IV. An example of the technique for building up from 1 ohm to 1 megohm is also shown in Section IV.

## 2.1.3 Divider Calibration

To make precision linearity measurements of a voltage divider, it is necessary to first calibrate a standard voltage divider. Due to its excellent short term stability and its four-terminal construction which makes it simple to calibrate, the ESI Model SR 1010 is ideal for use as such a standard voltage divider.

The following outlines the procedure for calibrating the SR 1010 as a voltage divider with ten equal steps, using the data given on its calibration chart.

		A	B	C	D
		Deviation of Individual Resistors from Nominal	Deviation of Individual Resistors from Average (ppm)	Cumulative Sum of B (ppm)	Linearity Deviation at Tap (ppm)
		Individual (ppm)		0.0	0.0
INSP	R1	+2	+0.4	+0.4	0.0
	R2	+4	+2.4	+2.8	+0.3
	R3	-1	-2.6	+0.2	0.0
	R4	+4	+2.4	+2.6	+0.3
	R5	+5	+3.4	+6.0	+0.6
DATE	R6	-3	-4.6	+1.4	+0.1
	R7	+3	+1.4	+2.8	+0.3
	R8	-5	-6.6	-3.8	-0.4
TEMP	R9	+2	+0.4	-3.4	-0.3
	R10	+5	+3.4	0.0	0.0
SER NO.	R11				
	R12				
		10	16	SUM	
				1.6	AVERAGE

MAX. POWER 1 WATT/RESISTOR OR 5 WATT

Figure 2-2.

- 1) Add up the deviations from nominal of the first ten\* resistors of the SR1010.
- 2) Divide this sum by ten\* to find the average deviation.
- 3) Subtract the average deviation from each of the ten\* individual deviations.
- 4) Starting with the first deviation from average, sum up all the deviations from average through each of the ten taps. For example the cumulative sum for the third tap would be the sum of the first, second and third deviations from average, for the example shown in Figure 2-2 this would be  $0.4 + 2.4 - 2.6 = 0.2$ .
- 5) Divide each of the cumulative sums by ten\* to get the linearity deviation at each tap.

These are the values given in the first column of the calibration chart on the end of the SR1010, see Figure 2-2, column A.

See Figure 2-2, column B.

See Figure 2-2, column C. The last figure in this column should always be zero.

See Figure 2-2, column D.

The calibrated SR1010 can now be used as a standard divider for calibrating other dividers. The following outlines the procedure for comparing the two.

- 6) Connect the SR1010 and a micro-voltmeter to the divider to be calibrated as shown in Section 2.2.4.
- 7) Adjust the end correcting potentiometers as described in Figure 2-9 (b).
- 8) Connect the microvoltmeter between corresponding taps on the SR1010 and divider to be calibrated, and measure the deviation of the output of the unknown divider from the output of the SR1010 at each tap.

The linearity deviation of the unknown divider will be

$$L_{\text{unk}}^r = \frac{V_{\mu\text{V}}}{E_{\text{in}}} + L_{\text{std}}^r$$

where:

$L_{\text{unk}}^r$  is the linearity deviation of the unknown divider at the rth tap.

$V_{\mu\text{V}}$  is the reading of the microvoltmeter.

$E_{\text{in}}$  is the voltage applied to the input of the dividers.

$L_{\text{std}}^r$  is the linearity deviation of the SR1010 for corresponding tap (Column D).

---

\*Or n, for n resistors

## 2.2 CONNECTIONS

### 2.2.1 Single Resistor Or Series Group

The SR 1010 was designed for use as a four-terminal resistor. The four connections are made to the two pairs of binding posts at either end of any of the resistors. The resistors are internally connected in series; to connect to  $n$  resistors in series it is only necessary to connect to the opposite ends of the 1st and  $n$ th resistors, see Figure 2-3 (a).

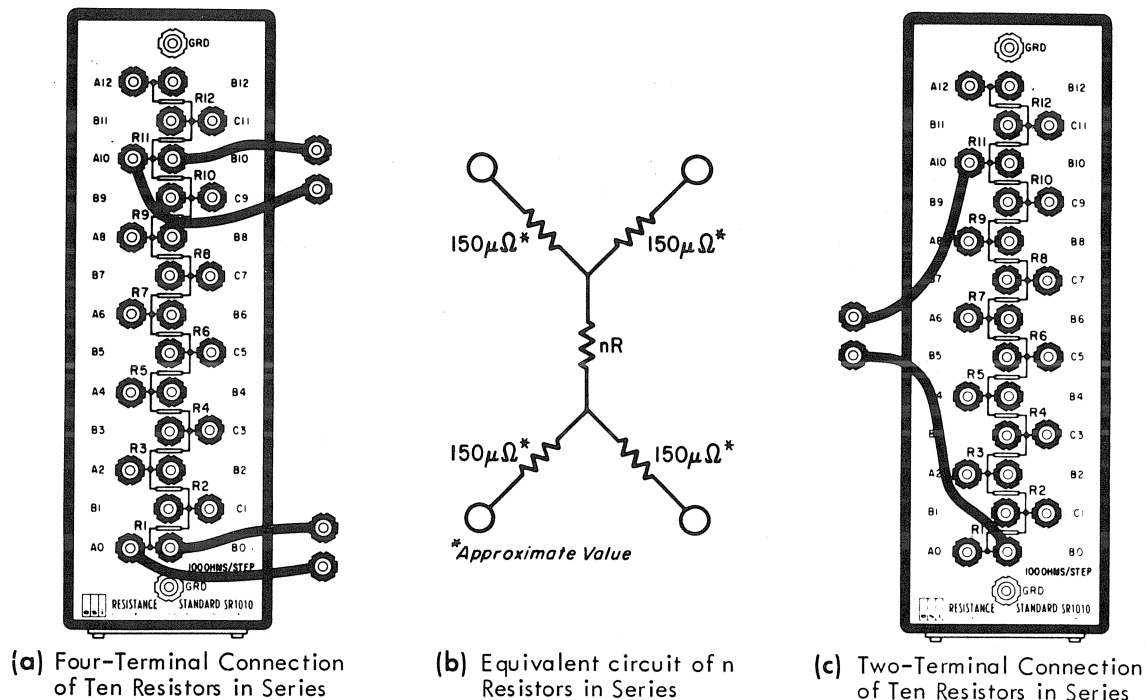

Figure 2-3.

The junction design that connects the resistors in series and to the binding post terminals is such that it contributes less than one microhm resistance to that of a four-terminal measurement of the individual resistors.

The SR 1010 may also be used as a two-terminal resistor; however, the calibrated four-terminal value must be corrected for the terminal resistance. Due to the design of the terminals at the end of each resistor it makes no difference which one is used for a two-terminal measurement. The resistance contributed by these terminals will be within  $\pm 0.06$  milliohms of the resistance measured between the pair of terminals connected to the same end of any resistor, (about 0.3 milliohms), see Figure 2-4.



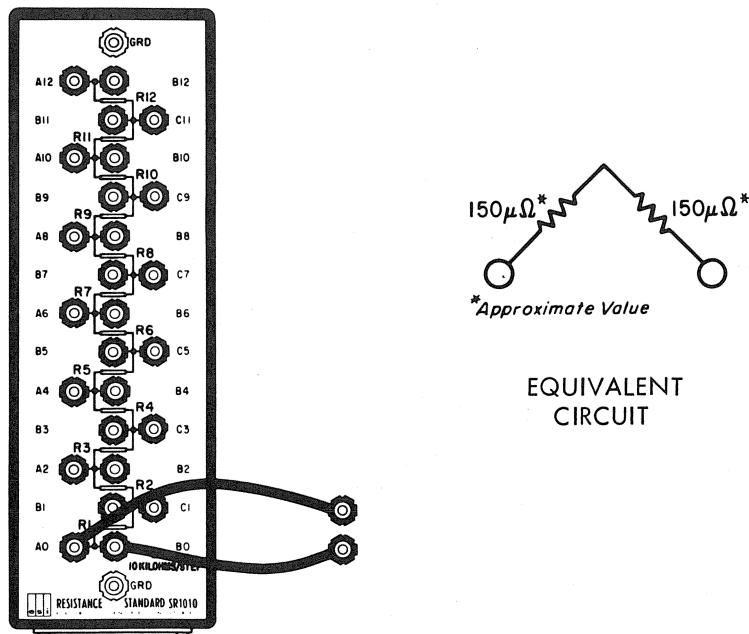

Figure 2-4.

### 2.2.2 Parallel Group Of Resistors

Any number of resistors of a SR 1010 can be connected in parallel by means of shorting bars (ESI Model SB 103 or equivalent), see Figure 2-5 (a). For individual resistors of less than one hundred ohms, the paralleling leads and contact resistance may cause significant errors.

In connecting ten resistors in parallel, these errors can be essentially eliminated by use of a special compensation network for making four-terminal parallel connections (ESI Model PC 101 Parallel Compensation Network), see Figure 2-5 (b).

It should be noted that the resistance in series with the terminals to the compensation network is considerably higher than that in series with the terminals to the shorting bars, see Figure 2-5 (b). When connecting this paralleled group of resistors and compensating network to a bridge or ratio set care should be taken to connect these higher resistance terminals where they will least affect the accuracy of the measurement.

A simplified four-terminal parallel connection of any number of resistors can be made using only the shorting bars as shown in Figure 2-6. This places a small connection resistance in series with the paralleled resistance. However, since there will be several contacts in parallel it will be a fairly stable and reproducible resistance and can be subtracted from the measured value.

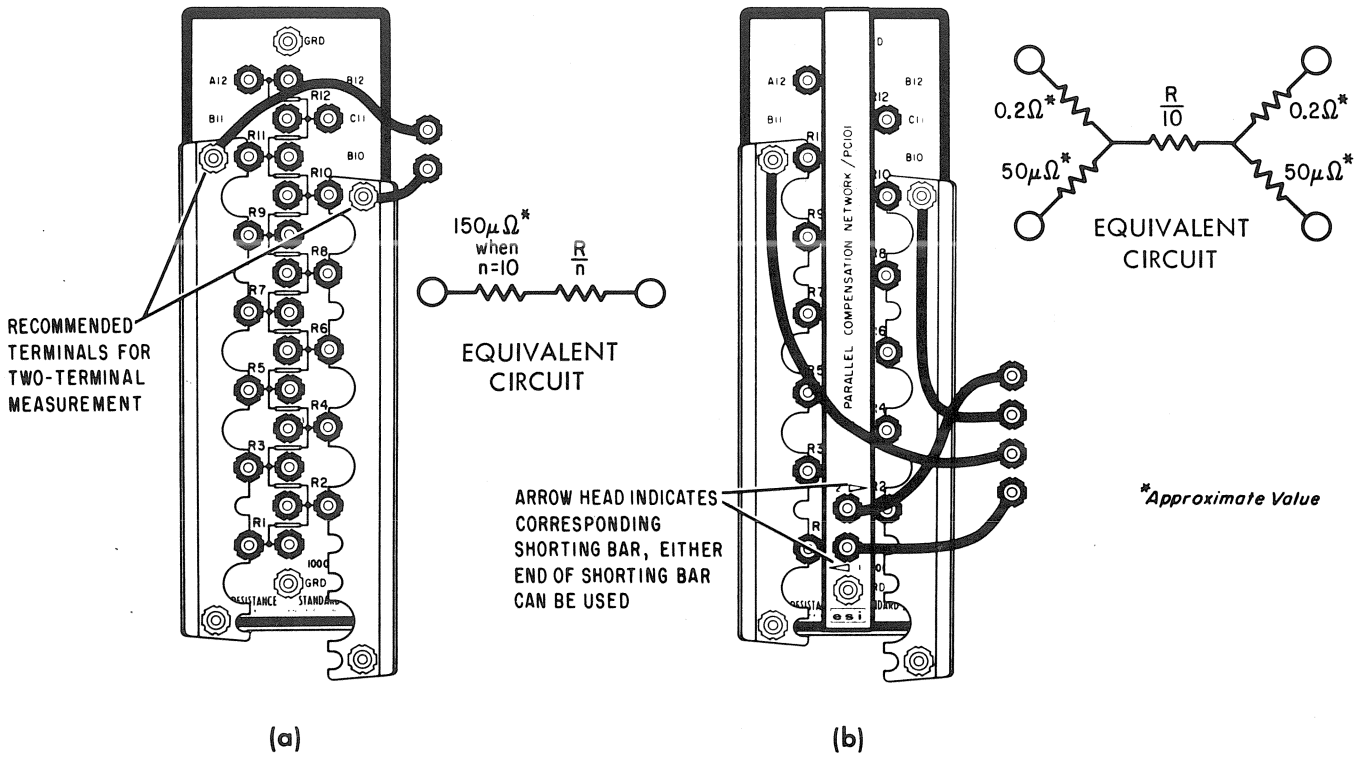

Figure 2-5.

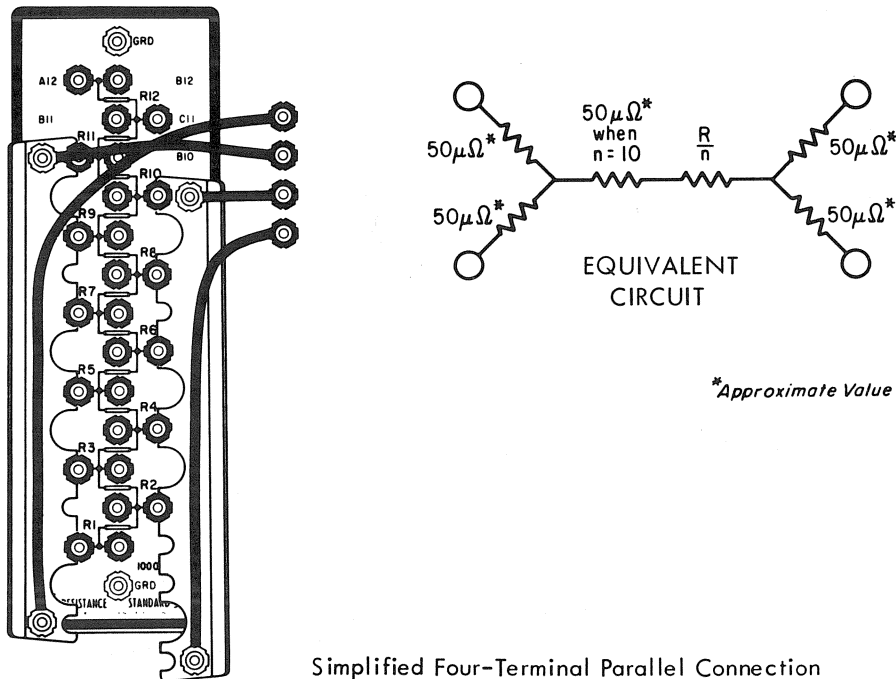

Figure 2-6.

### 2.2.3 Series-Parallel Group Of Resistors

In addition to the series and parallel connections, series-parallel connections of the SR 1010 are also possible. With this method nine resistors, three parallel groups of three resistors in series, may be used to form a stable resistor equal in value to the individual resistors in the string. The ESI Model SB 103 Shorting Bars can be used for this type of connection also, see Figure 2-7 (a). For individual resistors of less than one hundred ohms resistance, the paralleling leads and contact resistance may cause significant errors. These errors can be essentially eliminated by use of a special compensation network for making four-terminal series-parallel connections (ESI Model SPC 102 Series-Parallel Compensation Network). Such a network is shown connected to a SR 1010 in Figure 2-7 (b).

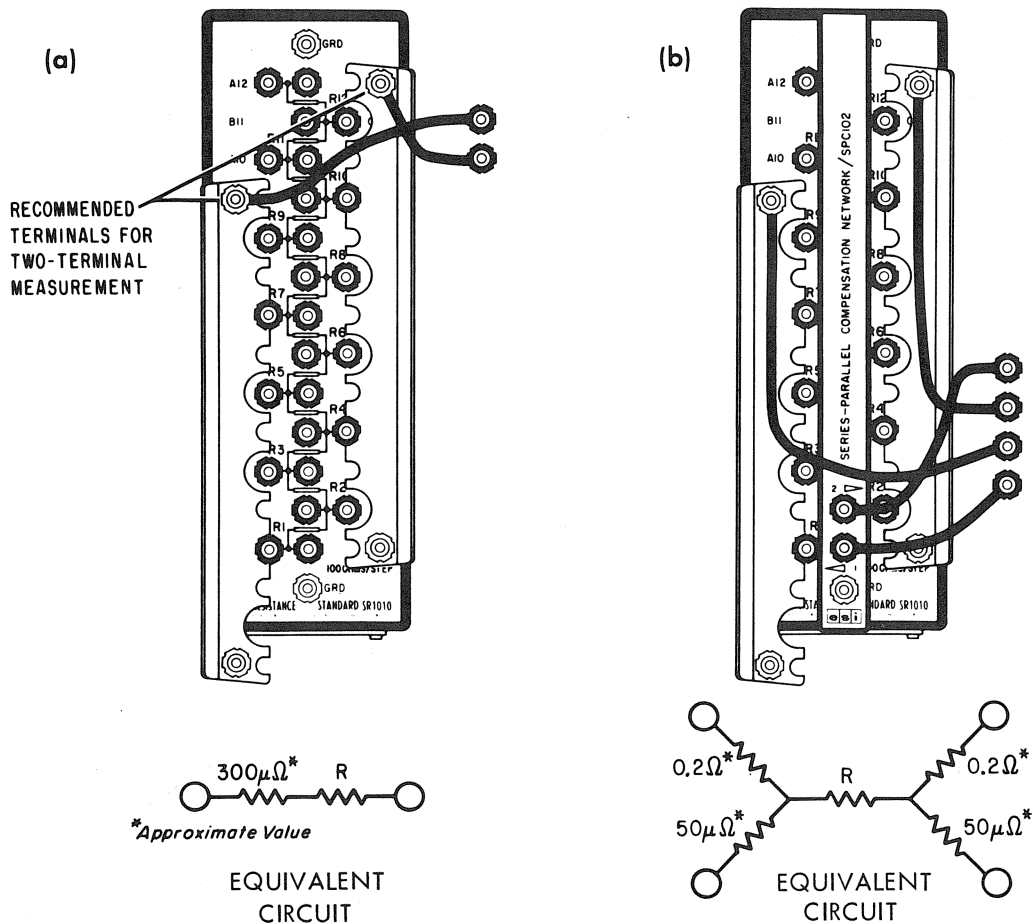
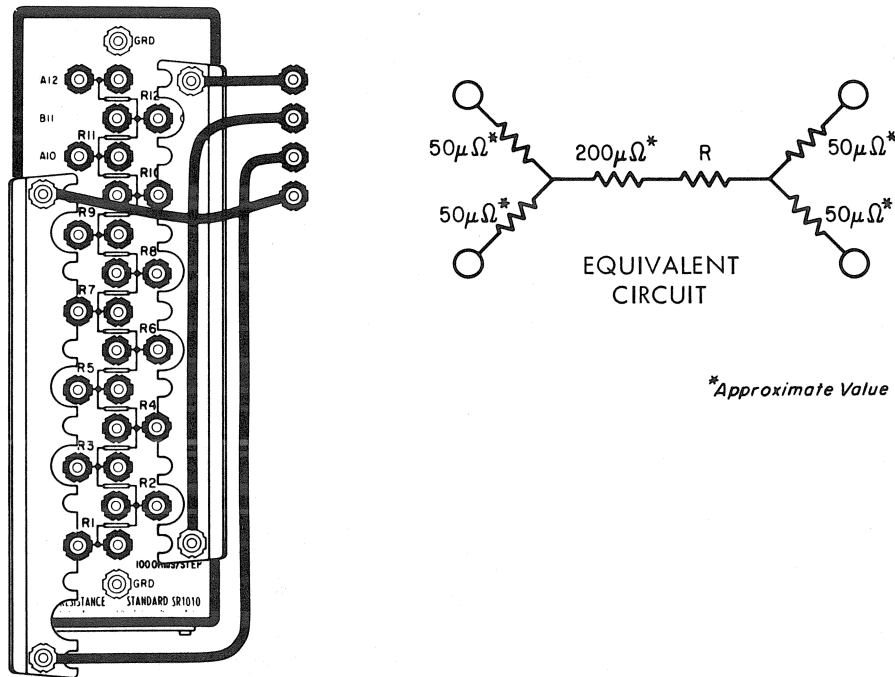

Figure 2-7.

It should be noted that the resistance in series with the terminals to the compensation network is considerably higher than that in series with the terminals to the shorting bars, see Figure 2-7 (b). When connecting this paralleled group of resistors and compensating network to a bridge or ratio set care should be taken to connect these higher resistance terminals where they will least affect the accuracy of the measurement.

A simplified four-terminal series-parallel connection can be made using only the shorting bars as shown in Figure 2-8. This places the connection resistance of the shorting bars in series with the series-paralleled resistance. However, since there will be several contacts in parallel it will be a fairly stable and reproducible resistance and could be subtracted from the measured value.



Simplified Four-Terminal Series-Parallel Connection

Figure 2-8.

#### 2.2.4 Divider Connections

Connections to the SR 1010 for use as a voltage divider should be made as shown in Figure 2-9 (a). The source is connected to terminals A0 and A10 and adjusted to the desired open circuit voltage at terminals B0 and B10. The rest of the taps will then be correct in interpolating between B0 and B10.

For calibrating another divider with a SR 1010 an additional accessory is required for compensating for lead and contact resistances, an ESI Model LC 875 Voltage Divider Lead Compensator or equivalent is recommended. The lead compensator is connected between terminals A0, A10 and the input of the divider to be calibrated, see Figure 2-9 (b). With the detector connected between B0 and the minimum end of the divider to be calibrated the lead compensator is adjusted for a detector null. Change the detector connections to B10 and the maximum end of the detector to be calibrated and adjust the lead compensator for a detector null. The divider to be calibrated may then be accurately compared to the SR 1010 at integral multiples of one tenth the full scale voltage.

For calibrating other than the first decade of a Kelvin-Varley voltage divider it is necessary to connect the generator to the input of the decade under calibration. This will normally require making an internal connection to the divider, see Figure 2-10. This method gives a complete, high accuracy calibration of the whole Kelvin-Varley divider, including all lead and switch resistances.

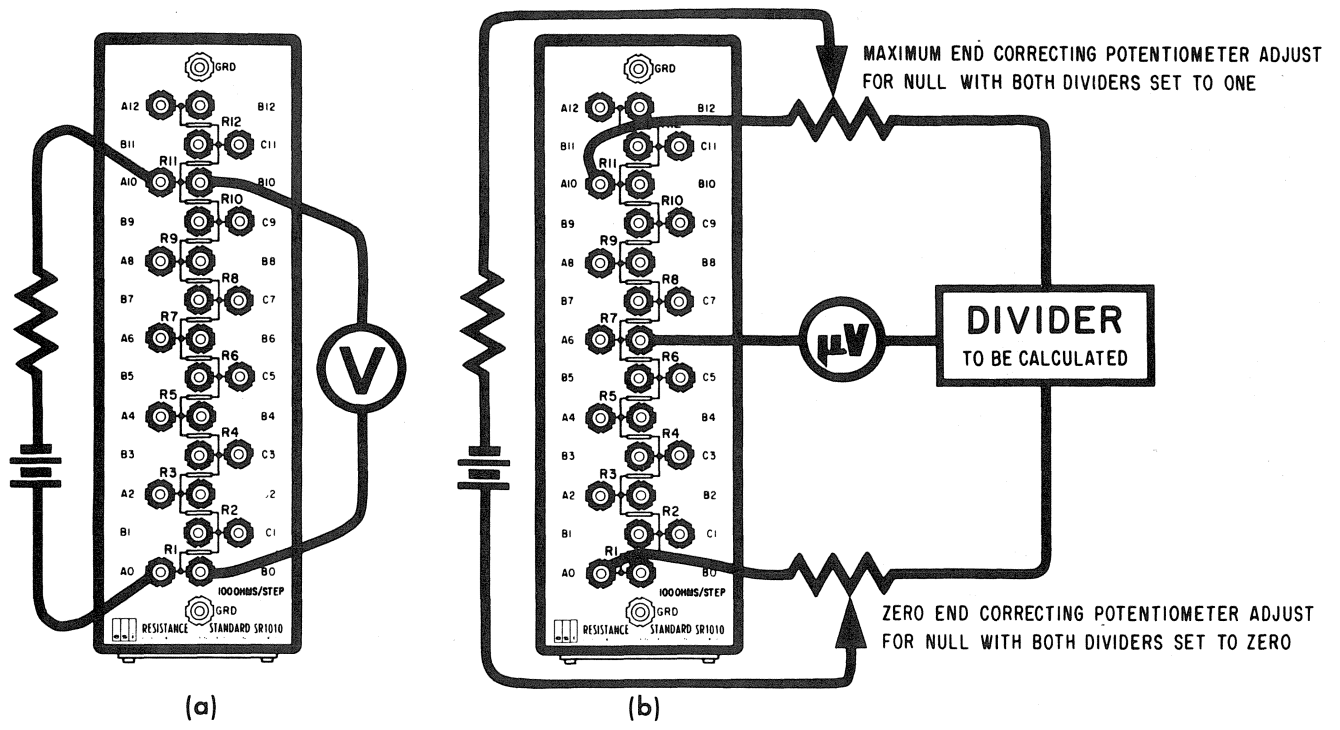

Figure 2-9.

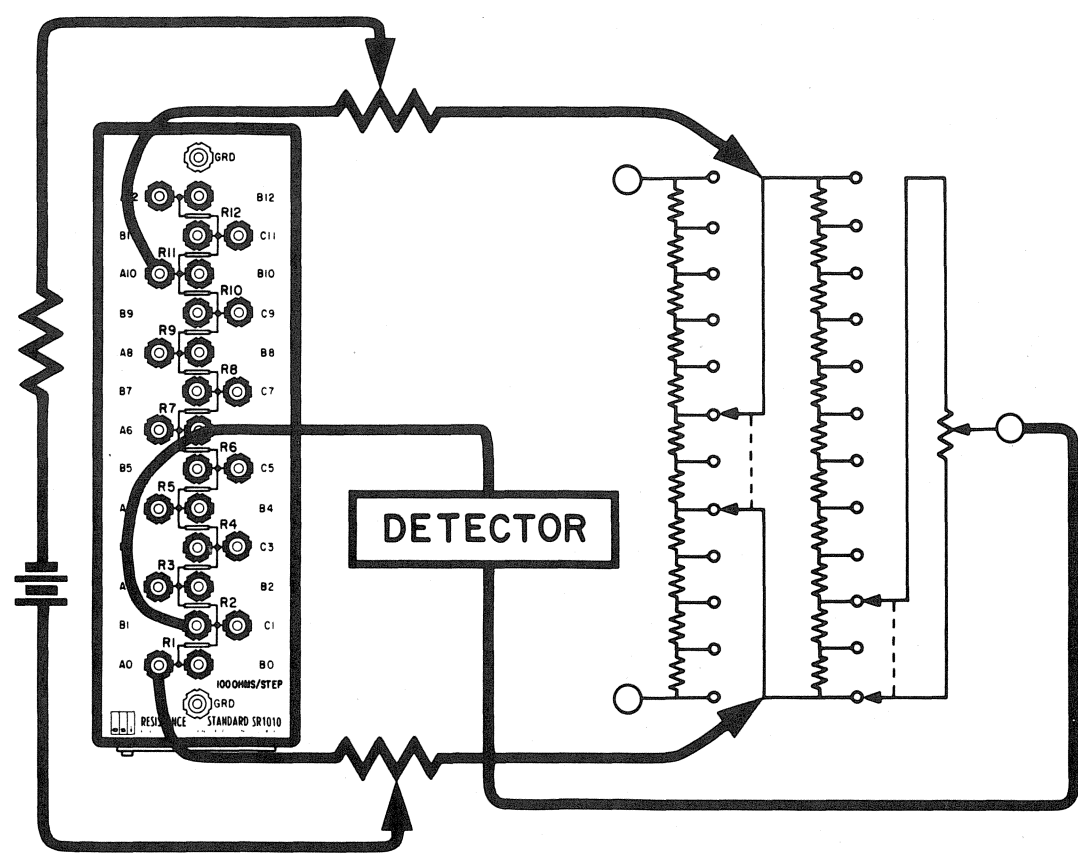

Figure 2-10.

## 2.3 HIGH ACCURACY CALIBRATION TRANSFER

### 2.3.1 Introduction

The name Resistance Transfer Standard refers to the ability of the Model SR 1010 to be measured at one resistance level and used with equal accuracy at a different resistance level. In a series of measurements using such transfers to trace calibration from a reference standard to an unknown resistor, neither the absolute value nor the long term stability of the resistors in the SR 1010s or the bridge used for comparisons has any effect on the measurement accuracy. The burden of calibration accuracy and long-term stability is placed on the reference standard alone; the concern with the rest of the system need be only with its short-term stability during the period of a few minutes required to complete the measurement. With careful operating technique in a normal laboratory environment, each step in such a series of measurements can be accurate to one or two ppm.

In making such a chain of measurements, one of the advantages of using a set of ten resistors connected as in the SR 1010 is that a 100 to 1 transfer in resistance level can be made at each measurement, minimizing the accumulation of errors. For example, the limits of error in measuring a 1-ohm resistor might be assumed as follows:

Certified accuracy of 10-kilohm standard	1 ppm
Comparison of 10-kilohm standard with 1-kilohm SR 1010 (connected for 10 kilohms)	2 ppm
Comparison of 1-kilohm SR 1010 with 10-ohm SR 1010/LTC (both connected for 100 ohms)	2 ppm
Comparison of 10-ohm SR 1010/LTC (connected for 1 ohm) with unknown 1-ohm resistor	2 ppm
Total	<hr/> 7 ppm

A similar procedure can be used to transfer from a 1-ohm standard to 10-kilohms and even to 1 megohm.

For highest accuracy, such a procedure may be repeated each time a new measurement is made. If, during such measurements, a record is kept of the calibration of each SR 1010 used, a quantity of data will soon be accumulated with a minimum of effort. This data will indicate the stability of the SR 1010 and/or the variations in calibration resulting from changes in ambient conditions, operators or techniques. It can serve to indicate the actual accuracy of the data on the calibration chart under the laboratory conditions prevailing, and it will indicate when it is time to replace the calibration chart and supply dependable data for a new chart.

### 2.3.2 Making Equal Resistance Comparisons

The comparison of like resistance values can be made independent of the absolute accuracy and long-term stability of the comparison bridge by using either an interchange or a substitution method. A direct-reading double ratio set such as ESI Model 240 or 240C Kelvin Ratio Bridge or ESI Model 120 Direct Reading Double Ratio Set should be used for calibration transfer with SR 1010s. These instruments can be used to make four-terminal comparison measurements with resolution and short-term stability between 1 ppm and 0.1 ppm.

The following outlines the procedure for comparing two resistors by the interchange method:

- 1) With the standard resistor or previously calibrated SR 1010 connected to the standard terminals of the bridge and the unknown resistor or SR 1010 to be calibrated connected to the unknown terminals, balance the bridge and determine the deviation of the unknown from the standard. Call this reading  $d_1$ .
- 2) With the unknown resistor connected to the standard terminals and the standard resistor connected to the unknown terminals, balance the bridge and determine the deviation of the standard from the unknown. Call this reading  $d_2$ .
- 3) Calculate  $\frac{d_1 - d_2}{2}$ . This is the deviation of the unknown resistor from the standard resistor. To obtain the deviation of the unknown resistor from nominal value, add to this calculated value the deviation of the standard resistor from nominal value.

To compare two resistors by the substitution method, connect to the standard terminals of the bridge a working standard resistor of the required value and make two measurements, the first with the standard resistor or previously calibrated SR 1010 connected to the unknown terminals, and the second with the unknown resistor or SR 1010 to be calibrated connected to the unknown terminals. The difference between these two readings will be the difference between the two resistors.

The substitution method is particularly convenient when either the working standard or the bridge ratio can be adjusted to make the bridge deviation dial read deviation from nominal value directly. The procedure is then modified so that when the known resistor is connected to the unknown terminals, the deviation dial is adjusted to its known deviation from nominal value and the working standard or ratio calibration adjustment is used to balance the bridge. When the known resistor is disconnected and the unknown connected to the unknown terminals, the deviation dial at balance will indicate directly the deviation of the unknown resistor from nominal value.

In a series of calibration transfer measurements in which the unknown resistance in one comparison and the known resistance in the next consist of the same group of resistors differently connected, the deviation reading in the first comparison becomes the initial deviation setting for the next measurement. Thus the dial setting serves as a mechanical memory and indicates the actual deviation value through the whole series of measurements, including the final reading on the unknown resistor.

### 2.3.3 Primary Resistance Standards

It is necessary to begin any chain of measurements with a primary standard resistor with a value that is accurately known and highly stable. ESI Model SR 104 is such a resistor and is recommended for this purpose. The use of this resistor is quite simple and requires no additional equipment such as regulated-temperature-oil bath or high-accuracy thermometers. ESI Model SR 104 has an internal oil bath, a low temperature coefficient, and a sealed-in temperature probe. The value of the Model SR 104 is 10 kilohms  $\pm 5$  ppm, calibrated to  $\pm 1$  ppm.

Another commonly-used primary resistance standard is the Thomas-pattern 1-ohm resistor. It is well known for its long-term stability. The following suggestions will aid in making measurements at the 1-ohm level with maximum accuracy:

- 1) Operate the Thomas-pattern resistor in oil in order to minimize its temperature rise with power dissipation and to allow accurate measurement of the resistor temperature. If accurate temperature coefficient data is available for the resistor ( $\alpha$  and  $\beta$  terms), a small unstirred pot of oil at room temperature is quite adequate. Measure the oil temperature to an accuracy of  $\pm 0.2^\circ\text{C}$  and calculate the value of the resistor at this temperature.
- 2) To avoid internal heating of the standard and the SR 1010, use reduced input power to the bridge for the initial balance adjustment, then increase power to approximately one half watt (2/3 amp through standard and unknown) for only a few seconds, to make the final accurate balance adjustment. Both the Thomas pattern resistor and the SR 1010 will typically remain constant within 1 ppm for approximately 10 seconds at this power level.
- 3) When using 1-ohm SR 1010 Transfer Standards, complete their comparison with the reference standard and their use in calibrating higher value SR 1010s in as short a time as possible, in order to keep all the measurements at as nearly the same temperature as possible. The exact temperature of an SR 1010 in calibration transfer is unimportant, but its temperature must remain sufficiently constant throughout the procedure. This is particularly important with the 1-ohm boxes, since they have higher temperature coefficients than the higher value boxes.

In changing the connections to the SR 1010, avoid unnecessary handling, in order to minimize temperature changes.

#### 2.3.4 Calibration Transfer Between SR 1010 Transfer Standards

In calibration transfer measurements, the three most commonly used connection configurations for the SR 1010's are ten resistors in parallel, nine resistors in series-parallel, and ten resistors in series, yielding resistance values of 0.1, 1 and 10 times the individual resistor value. It is preferable to use one of these groups of resistors in preference to any single resistor, in order to minimize temperature rise with internal heating and to take advantage of averaging of temperature coefficients of the various resistors in the box.

The basic absolute resistance calibration of an SR 1010 Transfer Standard is accomplished by accurately measuring any one of these three connection configurations. Once the reference standard or a previously calibrated SR 1010 has been used to calibrate one of these three configurations for a Transfer Standard, the values for all other resistor configurations are obtained by calculation using this value with selected measurements of the resistors in the same Transfer Standard relative to one another or relative to the nine-resistor series-parallel configuration having the same resistance value.

For 1 ppm accuracy in calibrating or using the ten resistor parallel and nine resistor series-parallel configurations, the PC 101 and SPC 102 compensation networks must be used with the 1 ohm and 10 ohm Transfer Standards, and with the 100 ohm box unless a correction is made for terminal resistance. The simplified four-terminal connection using the SB 103 shorting bar pair alone is adequate for SR 1010s having values of 1 kilohm per step or higher (see Section 2.2).



The recommended sequence for calibration transfer to the various SR 1010s is as follows:

SR 1010 (Ohms per Step)	Connection	Number of Resistors	Compared to
100kΩ	Parallel	10	10-Kilohm Primary Standard (ESI Model 104)
10kΩ	Series-Parallel	9	
1kΩ	Series	10	
100Ω	Series	10	1-Kilohm-per-Step SR 1010 in Series-Parallel
10Ω (SR 1010/LTC)	Series	10	1-Kilohm-per-Step SR 1010 in Parallel
1Ω	Series	10	10 Ohm-per-Step SR 1010 in Series-Parallel

### 2.3.5 Calibration Transfer Between Principal Configurations

The majority of calibration transfer applications require the use of only the three principal resistance configurations for the SR 1010 boxes; for these measurements, the individual resistors need never be calibrated. This is the key to both the high accuracy and the extreme simplicity of this transfer technique.

The basic rule relating resistor configurations is that all configurations which use the same group of resistors and distribute the power equally among them have the same deviation from the nominal values for the configurations; this deviation is equal to the average of the deviations of the individual resistors in the group from their nominal value. (This is true to one part in  $10^9$  for the resistor matching used in SR 1010s).

Thus ten resistors in series will have exactly 100 times the resistance of the same ten resistors in parallel, or nine resistors in series-parallel will have exactly nine times their resistance in parallel, or exactly one ninth of their resistance in series. Thus when a resistor group is calibrated in one configuration and exactly the same group used in another configuration at a different resistance level, no further measurements are necessary and no calculations are required.

To transfer calibration between the ten resistor group and the nine resistor group, the difference between the tenth resistor and the nine-resistor series-parallel configuration must be measured\* in order to calculate the average deviations of the two groups.

$$d_{av}^9 - d_{av}^{10} = 0.1 (d_{av}^9 - d_{10})$$

---

\*For transfer standard values requiring the use of the compensation networks, this measurement must be made by the substitution method rather than the interchange method, since the network must be removed to connect to the tenth resistor for measurement.

in which:

$d_{av}^9$  is the average deviation of the nine resistor group from nominal.

$d_{av}^{10}$  is the average deviation of the ten resistor group from nominal.

$d_{10}$  is the deviation of the tenth resistor from nominal.

$(d_{av}^9 - d_{10})$  is the measured difference between the nine resistor series-parallel configuration and the tenth resistor.

This formula can be visualized as a weighted average on a diagram as follows:

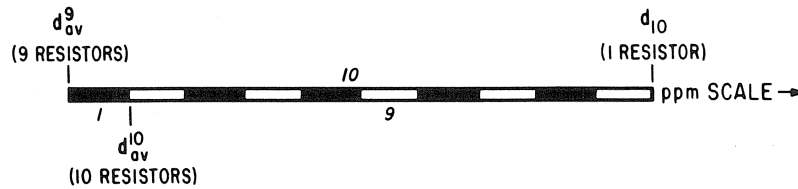

Note that the measured difference is multiplied by one tenth; thus if the measurement by the substitution method is accurate to 1 or 2 ppm, the calculated difference between the groups will be correct to 0.1 or 0.2 ppm, which can be considered negligible compared with the accuracy to which the measured group is known.

### 2.3.6 Calibration Transfer To Individual Resistors

To calibrate the individual resistors of an SR 1010 it is recommended that the deviation from nominal of a series or parallel group of ten, or a series-parallel group of nine be determined as accurately as possible by comparison to a known reference standard. Next each of the individual resistors must be compared to a stable working standard to determine their deviations relative to one another. From these relative deviations the average deviation for the group first measured is calculated. The difference of this measured deviation from nominal minus the calculated average deviation is added to each of the individual deviations to determine the deviation from nominal of the individual resistors. (See also subsection 2.4).

### 2.3.7 Calibration Of An SR 1010 As A Ten-Step Divider

Since ratio measurements do not depend upon any absolute resistance standard, no reference standard of resistance is required to calibrate an SR 1010 as a divider. The procedure for calibrating an SR 1010 as a divider with ten equal steps is as follows:

- 1) Connect a stable working standard, whose nominal value is equal to that of the individual resistors of the SR 1010 to be calibrated, to the standard terminals of the bridge.

This standard may be ten resistors in series (or parallel) of the SR 1010 whose resistance per step is one tenth (or ten times) that of the SR 1010 to be calibrated.

- 2) Measure  $d_n$ , the deviation of each of the first ten resistors in the string from that of the standard resistor.
- 3) Calculate the average deviation  $d_{av}^{10}$ , of the ten measured deviations,  $d_n$ .
- 4) Subtract the average deviation,  $d_{av}$  from each deviation  $d_n$ .
- 5) Sum these differences to each tap and divide by ten to get the linearity deviation at the tap.

The calibration of the bridge or the accuracy of the working standard need not be considered, only their short term stability is of importance.

$$d_{av}^{10} = 0.1 \sum_{n=1}^{10} d_n$$

$$(d_n - d_{av}^{10})$$

$$L_r = 0.1 \sum_{n=1}^{n=r} (d_n - d_{av}^{10})$$

where:

$L_r$  (ratio error) is the linearity deviation at the  $r$ th tap. Linearity deviation is defined as the difference between actual tap value and nominal tap value expressed as a proportional part of full scale.

A sample tabular calculation of steps 3), 4), and 5) is shown in Figure 2-2.

## 2.4 CALIBRATION OF INDIVIDUAL RESISTORS

The following procedure can be used to verify the calibration of the calibration card or to supply data for a new card. This procedure should be performed only by those who have the necessary facilities. Calibration should be performed in a laboratory environment with a resistance measuring system of the required sensitivity and accuracy, and with a primary resistance standard for which the resistance is adequately known.

- 1) Calibrate the resistance measuring system at the resistance of the steps of the transfer standard to be calibrated.
- 2) Measure each resistor in the transfer standard.
- 3) Record the deviation from nominal of each resistor and correct the reading (if necessary) for the error of the measuring system.
- 4) Round the corrected deviations of the individual resistors to the nearest ppm and enter the value in the first column of the calibration card.
- 5) Sum the individual deviations from the first to each of the subsequent deviations.
- 6) Divide the cumulative sum by the number of resistors involved in the sum.
- 7) Round the cumulative averages to the nearest ppm and enter them in the second column of the calibration card.

This calibration can be done using resistance transfer standards that have uncalibrated individual resistors. Paragraph 2.3.6 describes a method of doing so.

The exact method of measuring resistors depends on the measurement system. The system should have direct readout in parts per million.

See Figure 2-11, columns A and B for an example.

See Figure 2-11 for an example. If the deviations of the individual resistors are the same as recorded on the calibration card, no further calculations are necessary.

See Figure 2-11, column C. For example, the cumulative sum corresponding to R4 is the sum of the deviations of R1, R2, R3, and R4.

See Figure 2-11, column D. For example, the cumulative average corresponding to R4 is the cumulative sum divided by 4.

See Figure 2-11 for an example.

	A	B	C	D
	Measured Individual Deviations	Corrected Individual Deviations	Cumulative Sum	Cumulative Average
R1	+3.6	+2.1	+2.1	+2.1
R2	+5.7	+4.2	+6.3	+3.2
R3	+0.3	-1.2	+5.1	+1.7
R4	+5.3	+3.8	+8.9	+2.2
R5	-1.6	-3.1	+5.8	+1.2
R6	+4.9	+3.4	+9.2	+1.5
R7	+4.5	+3.0	+12.2	+1.7
R8	-3.2	-4.7	+7.5	+0.9
R9	+4.0	+2.5	+10.0	+1.1
R10	+6.6	+5.1	+15.1	+1.5
R11	+3.2	+1.7	+16.8	+1.5
R12	-2.7	-4.2	+12.6	+1.0

		SR1010 OHM/STEP	
		ELECTRO SCIENTIFIC INDUSTRIES U.S.A.	
		DEVIATION FROM NOMINAL	
		Individual (ppm)	Cumulative (ppm)
INSP	R1	+2	+2
	R2	+4	+3
	R3	-1	+2
	R4	+4	+2
	R5	-3	+1
DATE	R6	+3	+2
	R7	+3	+2
	R8	-5	+1
TEMP	R9	+2	+1
	R10	+5	+2
	R11	+2	+2
SER NO.	R12	-4	+1

MAX POWER 1 WATT/RESISTOR OR 5 WATT TOTAL

TRACEABLE TO U.S. NATIONAL BUREAU OF STANDARDS

CONTRACT NO. FSN 6625

Figure 2-11.

## SECTION III THEORY

### 3.1 JUNCTION RESISTANCE EFFECTS

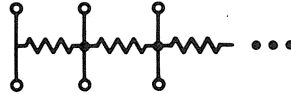

Figure 3-1.

The series configuration of the SR 1010 Transfer Standard is shown in Figure 3-1. The four-terminal resistors can be measured individually or in any series combination. If the measured series resistance is to be equal to the sum of the individual resistor measurements, the junctions must have zero four-terminal resistance. This junction transresistance is zero if a current source connected to any two of the four-junction terminals produces zero voltage difference between the other two terminals.

The junction design used in the SR 1010 (Figure 3-2)\* has a theoretical transresistance of zero. If a current source is connected to any two terminals of this junction, the other two terminals will always be on an equipotential line. In practice, as a result of manufacturing tolerances, the junctions may have some transresistance. This can be measured.

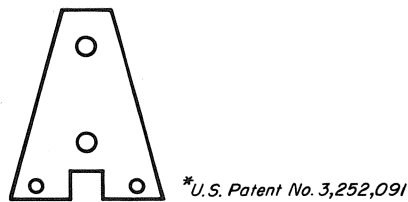

Figure 3-2.

The tests for a four-terminal point junction are shown in Figure 3-3 (a and b). The meter voltages divided by the generator currents are the transresistances for the two connections shown. A third transresistance, shown in Figure 3-3 (c) need not be measured, since it is always equal to the difference between the other two (note that each reading in Figure 3-3 (a and b) may be either positive or negative; keep this sign when subtracting to calculate the third transresistance).

These three transresistances represent the greatest possible resistance measurement error. For the junction in the SR 1010 each of these three resistances is less than 0.5 microhm, causing much less than one ppm error for even a 1-ohm-per-step transfer standard.

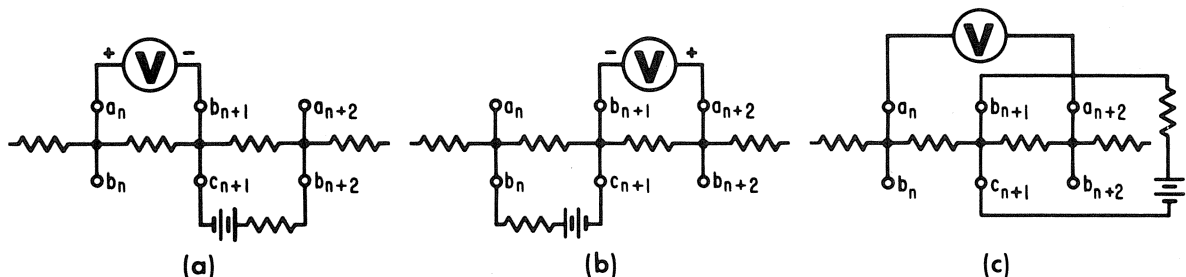

Figure 3-3.

### 3.2 INSULATION RESISTANCE EFFECTS

The leakage resistance of the SR 1010 to its case is in excess of  $10^{12}$  ohms. For worst case conditions (twelve one hundred kilohm resistors in series with one end of the SR 1010 tied to its case) the error due to shunt resistance will be less than 1.2 ppm.

If a three-terminal measurement is made (the case being the third terminal) and again worst case conditions assumed (twelve resistors in series with all leakage being concentrated from the center point of the series string) the following wye-delta transformation is necessary to determine the resulting error.

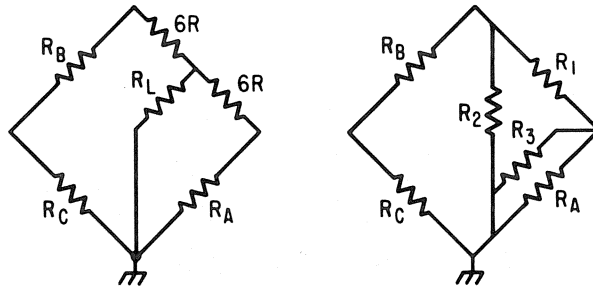

Figure 3-4.

where:

$R_A$ ,  $R_B$  and  $R_C$  are the ratio arms of the bridge.

$R$  is the resistance per step of the SR 1010

$R_L$  is the leakage resistance from the SR 1010 to its case.

$$R_1 = \frac{36R^2}{R_L} + 12R = 12R \left( 1 + \frac{3R}{R_L} \right)$$

$R_2$  is across the generator or detector so can be neglected.

$$R_3 = 2R_L + 6R$$

For a one hundred kilohm per step box  $R_1 = 12R (1 + 0.3 \text{ ppm})$  and  $R_3 = 2 \times 10^{12}$ .

If  $R_A$  is no greater than one hundred kilohms the error will not exceed 0.3 ppm.

Since leakage resistance will lower the measured resistance in a two-terminal measurement and increase it in a three-terminal measurement the actual resistance must lie between these two values. This fact can be used as a check to determine the magnitude of the error due to leakage resistance.

### 3.3 BASIC TRANSFER ACCURACY

To make transfer measurements which do not depend on the absolute accuracy of the transfer standard but only on its short term stability, it is necessary to assume that ten resistors in parallel are exactly equal to one one-hundredth of the same ten resistors in series. To see how valid this assumption is let  $R$  be the nominal value of the individual resistors and  $d_n$  the deviation from nominal of this  $n$ th resistor. The value of the  $n$ th resistor will then be  $R_n = R(1 + d_n)$ . The value of the ten resistors in series will be:

$$R_s = \sum_{n=1}^{10} R(1 + d_n) = 10R \left( 1 + \frac{1}{10} \sum_{n=1}^{10} d_n \right)$$

$$d_{av}^{10} = \frac{1}{10} \sum_{n=1}^{10} d_n$$

where:

$d_{av}^{10}$  is the average of the deviation  $d_n$  for ten resistors.

$$R_s = 10R \left( 1 + d_{av}^{10} \right)$$

The resistance of the same ten resistors in parallel will be:

$$R_p = \frac{1}{\sum_{n=1}^{10} \frac{1}{R(1 + d_n)}}$$

$$\frac{1}{R(1 + d_n)} = \frac{1}{R} (1 - d_n + d_n^2 - d_n^3 \dots)$$

$$R_p = \frac{1}{\sum_{n=1}^{10} \frac{1}{R} (1 - d_n + d_n^2 \dots)}$$

$$R_p = \frac{R}{10} \frac{1}{1 + \frac{1}{10} \sum_{n=1}^{10} (-d_n + d_n^2 \dots)}$$

$$R_p = \frac{R}{10} \left( 1 + \frac{1}{10} \sum_{n=1}^{10} d_n - \frac{1}{10} \sum_{n=1}^{10} d_n^2 \dots \right)$$

$$R_p = \frac{R}{10} \left( 1 + d_{av}^{10} - \frac{1}{10} \sum_{n=1}^{10} d_n^2 \dots \right)$$

$$R_p \approx \frac{R}{10} \left( 1 + d_{av}^{10} \right)$$

The assumption being that  $\frac{1}{10} \sum_{n=1}^{10} d_n^2$  is negligible. Since  $d_n$  maximum for the SR1010 is less than 100 ppm  $d_n^2$  will be less than 0.01 ppm which can be neglected, thus the original assumption is quite valid. A similar analysis can be made for the series-parallel connection or any other configuration in which the power divides equally among the resistors.

### 3.4 FOUR-TERMINAL PARALLELING

The parallel connection of ten four-terminal resistors is shown in Figure 3-5.

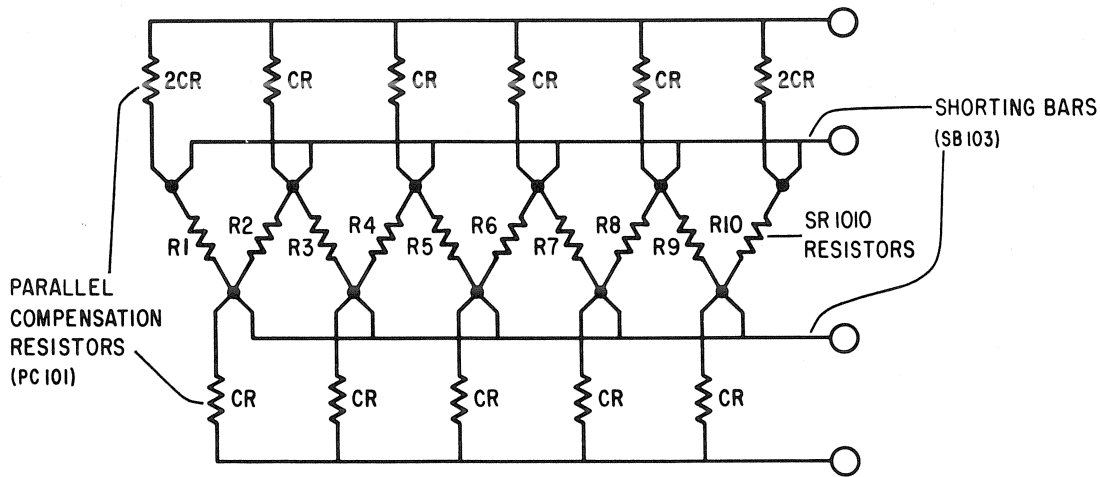

Figure 3-5.

The shorting bar resistance and the resistance from the junctions to the shorting bars should be small. The parallel-compensation resistors should be large compared to the uncertainty in the contact resistances when they are connected and should be proportional to the resistance of the SR 1010 resistors. The two parallel-compensation resistors on the ends are double the others because they connect to one build-up resistor instead of two in parallel.

When several nominally equal resistors are connected in parallel the connection accuracy can be analyzed by assuming all of the compensation resistors except one are equal, and that all of the bus bar resistances except one are zero. At the same time all of the resistors being connected are assumed to be perfect except one. The three imperfect resistors all meet at one of the junctions. Since small first-order error effects add linearly the results of this analysis can be extended to determine the connection accuracy. The connection uncertainty is less than:

$$\pm 2 \left( \frac{r}{R} \right) (d_{CR} - d_R)$$

where:

$r$  is the greatest bus bar resistance

$R$  is the nominal value of resistors being parallel connected

$(d_{CR} - d_R)$  is the greatest bridge unbalance in terms of resistance deviations of the compensation resistors and the resistors being connected.

The values of  $\frac{r}{R}$  and  $(d_{CR} - d_R)$  can be measured to find the expected accuracy of a particular connection.



The value of  $\frac{r}{R}$  can be found by measuring the voltage drops from a point on the bus bars to the junction  $\frac{r}{R}$  of adjacent resistors, shown in Figure 3-6.

Connect the shorting bars.

Measure voltage from a point on the bars to the unused terminals. This is the voltage to the junction of adjacent resistors.

Find the maximum difference of values  $V$  for each bar.

Use the greatest  $V$  difference to calculate  $\left(\frac{r}{R}\right)_{\max}$

$$\text{for } r \ll R \quad \frac{V_{\max} - V_{\min}}{E} \approx \left(\frac{r}{R}\right)_{\max}$$

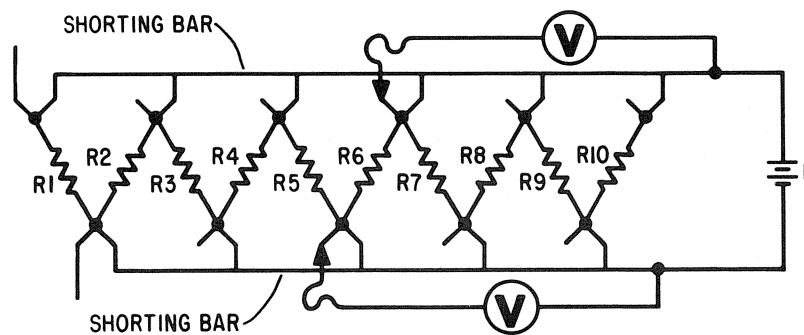

Figure 3-6.

Connect the compensating network.

Connect the shorting bar.

Supply a voltage E from the shorting bar to the other side of the network.

Measure the voltage V from one unused shorting bar terminal to each of the others.

Change the shorting bar to the other side and repeat.

Find the maximum voltage difference ( $V_{\max} - V_{\min}$ ) between terminals.

Calculate  $(d_{CR} - d_R)_{\max}$

$$\left( \frac{V_{\max} - V_{\min}}{E} \right) \left( 2 + \frac{2CR}{R} + \frac{R}{CR} \right) = (d_{CR} - d_R)_{\max}$$

The measured values of  $\left( \frac{r}{R} \right)_{\max}$  and  $(d_{CR} - d_R)_{\max}$  can be multiplied together and doubled to give an upper bound of the connection error. This usually includes a very substantial safety factor. The same technique can be used in the series-parallel case.

*NOTE: With paralleling and series-paralleling accessories, Models PC 101 and SPC 102, these effects should always be negligibly small.*

The bridge unbalance can be measured as shown in Figure 3-7.

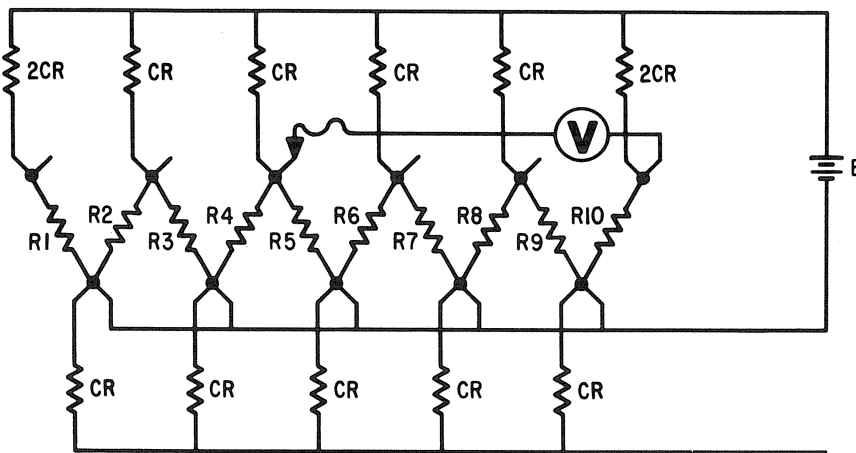

Figure 3-7.

### 3.5 LINEARITY DEVIATION

To calibrate the SR1010 as a voltage divider we need to know the difference between the actual ratio of the output to input voltages and the setting. This difference is called linearity deviation.

$$L = \frac{E_{out}}{E_{in}} - S$$

L - linearity deviation

$E_{in}$  - actual input voltage

$E_{out}$  - actual output voltage

S - divider setting

Since the voltage and resistance divide proportionately, the linearity deviation can be found by a precision comparison of the resistors in the divider string. By using ten resistors of the SR 1010 in the divider string, the output can be set to integral multiples of a tenth the input voltage. The linearity deviation for this divider can be written as:

$$L = \frac{\sum_{n=1}^{105} R_n}{\sum_{n=1}^{10} R_n} - S$$

L - linearity deviation

$R_n$  - resistance of nth resistor

$\sum_{n=1}^{105} R_n$  - resistance from COM to OUT in ohms

$\sum_{n=1}^{10} R_n$  - total input resistance in ohms

S - divider setting

If all of the resistors in the string were equal, the voltage would divide equally. To find how far from the ideal this divider is each resistor,  $R_n$ , of the string is compared to a standard resistor. To maintain the ultimate in measurement accuracy four-terminal measurements should be made. The measured resistance deviation is used to calculate the linearity deviation.

$$R_n = R_s (1 + d_n)$$

$R_n$  = resistance of nth resistor in ohms.

$R_s$  = resistance of standard resistor in ohms

$d_n$  = per unit deviation of  $R_n$  from  $R_s$

This leads to the following expression for linearity deviation:

$$L = \frac{\sum_{n=1}^{105} (1 + d_n)}{\sum_{n=1}^{10} (1 + d_n)} - S$$

The precise value of the standard resistor is unimportant since it is canceled out of the equation, thus any one of the resistors of the string can be used as the standard resistor. To simplify calculations the equation for linearity deviation can be modified by first defining the average deviation as  $d_{av}^{10} = 0.1 \sum_{n=1}^{10} d_n$  and then assuming  $d_{av}^{10}$  is much smaller than one. The equation for linearity deviation can then be expressed as follows:

$$L = 0.1 \sum_{n=1}^{105} (d_n - d_{av}^{10})$$

## SECTION IV APPLICATIONS

This section illustrates applications of the Model SR1010 Transfer Standards by describing step-by-step resistance transfer procedures for typical instruments. The transfer techniques may be used as a method of calibrating the individual resistors in a transfer standard, to calibrate other resistors, or to calibrate the measuring instruments themselves.

The techniques shown here are intended as examples. They illustrate the way that the Model SR1010 Transfer Standards can be used. One can adapt the techniques illustrated here to other equipment.

### 4.1 RESISTANCE TRANSFER WITH ESI MODEL 123 RESISTANCE COMPARISON SYSTEM\*

#### 4.1.1 System Description

ESI Model 123 Resistance Comparison System consists of ESI Models 120 Direct-Reading Double Ratio Set, 876 Lead Compensator, 830 Generator, and 900 Galvanometer. This system uses

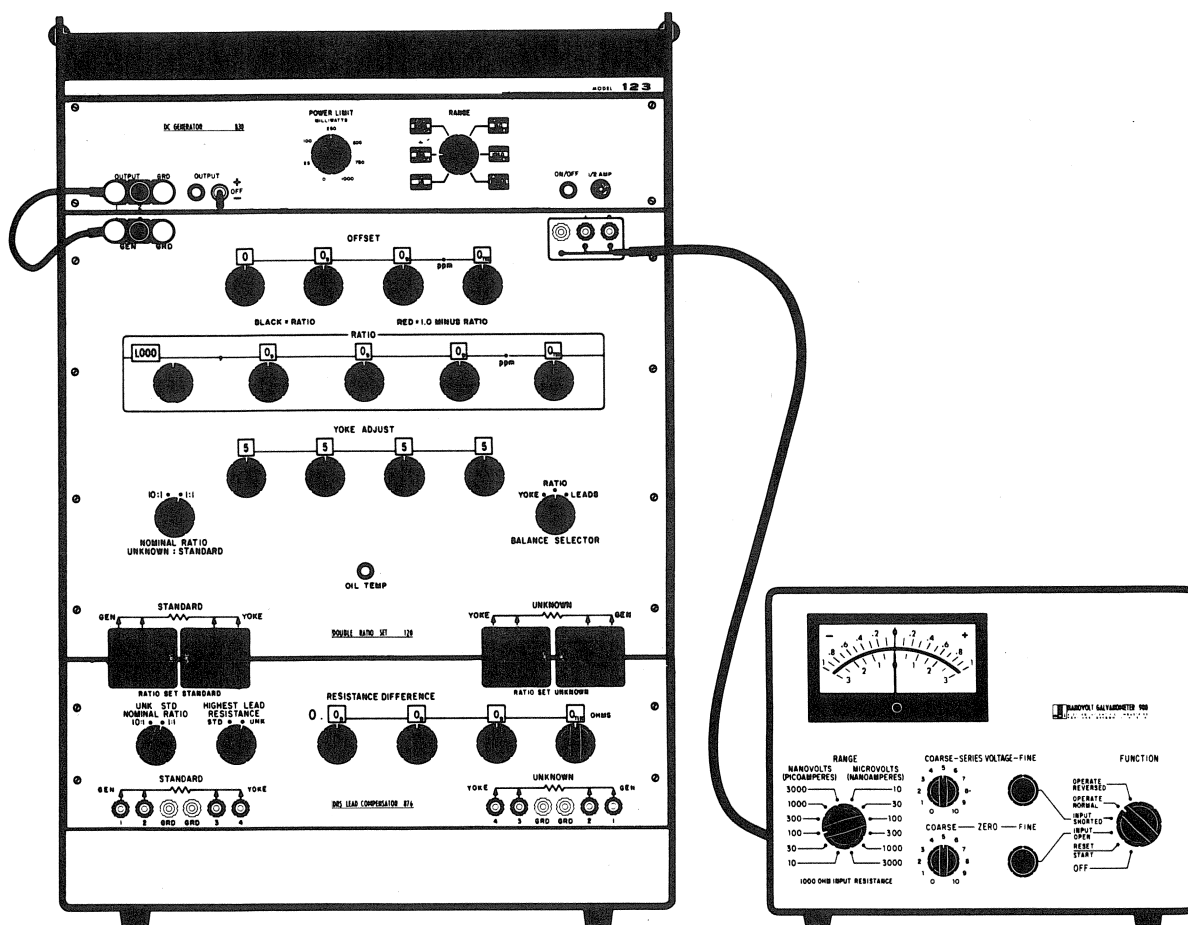

Figure 4-1.

\*The Model 123 is no longer being manufactured.

a Wenner balance technique that eliminates errors due to resistance of the test leads. The resolution of the ratio set is 0.1 ppm per step of the OFFSET and RATIO dials and the galvanometer can be used to interpolate to 0.01 ppm throughout much of the range.

The accuracy of comparisons can be illustrated by the following example, in which a 10-kilohm standard value is transferred to 1 ohm. The error of each step of the transfer procedure is independent of the other steps and so the combination of errors is shown as the square root of the sum of the squares of the individual errors.

This example is taken from paragraph 4.1.5 following. The individual limits of error are those specified for the equipment used.

<u>Source of Error</u>	<u>Individual Limit of Error (ppm)</u>
1. Primary Standard (ESI Model SR104 10-kilohm Resistance Standard)	1.0
2. Comparison of Resistance Standard to tare resistor (using ESI Model 123 System)	0.22
3. Comparison of tare resistor to 1-kilohm-per-step transfer standard (SR 1010)	0.22
4. 100-to-1 transfer	1.0
5. Comparison of 1-kilohm-per-step transfer standard to 10-ohm-per-step transfer standard (SR 1010/LTC)	0.22
6. 100-to-1 transfer	1.1
7. Comparison of 10-ohm-per-step transfer standard to 1-ohm resistor	0.22
Square root of the sum of the squares	<hr style="width: 50%; margin: 0 auto;"/> 1.85 ppm

Exact details of operating the system are not covered in this procedure. The detector must be zeroed with the generator off but with the resistors to be compared connected to the UNKNOWN and STANDARD binding posts; the yoke and leads must be balanced according to the procedure in the manual for the ratio set; and the detector sensitivity must be increased after each trial balance. All of these operations are included in the single word "balance" in the following procedures.

#### 4.1.2 Transfer From 10 Kilohms to 100 Kilohms and 1 Kilohm

1. Connect the 10-kilohm primary standard resistor (ESI Model SR 104 is recommended) to the UNKNOWN binding posts of the lead compensator. Use a four-terminal connection to the resistor and connect at least one GRD terminal on the standard resistor to a GRD terminal on the bridge.
2. Set RATIO controls of the ratio set to the calibrated resistance of the standard. Be sure to correct this setting for temperature. (ESI Model SR 104 contains an internal resistance temperature sensor which changes by 0.1% per degree Celsius. A calibration curve is included with the standard resistor.)
3. Connect the tenth resistor (R10) of the 10-kilohm-per-step SR 1010 to the STANDARD binding posts of the lead compensator.
4. Balance the bridge with OFFSET dials. Do not adjust the RATIO dials. Record the reading of the OFFSET dials as d(10).
5. Connect the 10-kilohm-per-step SR 1010 in series-parallel (paragraph 2.2.3) and connect the transfer standard to the STANDARD terminals of the lead compensator.
6. Balance the bridge with the OFFSET dials. Do not adjust the RATIO dials. Record the reading as D(9).
7. Set the OFFSET dials to the calculated setting:

$$\frac{d(10) + 9D(9)}{10}$$

*NOTE: The following steps are for calibrating 100-kilohm resistors. If you wish to calibrate 1-kilohm resistors proceed to step 11.*

8. Disconnect shorting bars from the 10-kilohm-per-step SR 1010 and connect the first 10 resistors in series to the STANDARD terminals of the lead compensator.
9. Connect 100-kilohm resistor to be calibrated to the UNKNOWN terminals of the lead compensator.
10. Balance the bridge with the RATIO dials. The indication of the RATIO dials is the ratio of the 100-kilohm resistor to the actual value of 100 kilohms as transferred from the primary standard. (Only the last two steps need be repeated for each resistor of a group of 100-kilohm resistors.)

*NOTE: The following steps are for calibrating 1-kilohm resistors.*

11. Connect the first ten resistors of the 10-kilohm-per-step SR 1010 in parallel with the shorting bars. Connect the parallel combination to the STANDARD terminals of the lead compensator.
12. Connect 1-kilohm resistor to be calibrated to the UNKNOWN terminals of the lead compensator.

13. Balance the bridge with the RATIO dials. The indication of the RATIO dials is the ratio of the 1-kilohm resistor to the actual value of 1 kilohm as transferred from the primary standard. (Only the last two steps need be repeated for each resistor of a group of 1-kilohm resistors.)

#### 4.1.3 Transfer From 10 Kilohms to 100 Ohms

1. Connect the 10-kilohm primary standard resistor (ESI Model SR104 is recommended) to the UNKNOWN binding posts of the lead compensator. Use a four-terminal connection and connect at least one GRD terminal on the standard resistor to a GRD terminal on the bridge.
2. Set RATIO controls of the ratio set to the calibrated resistance of the standard. Be sure to correct this setting for temperature. (ESI Model SR 104 contains an internal resistance temperature sensor which changes by 0.01% per degree Celsius. A calibration curve is included with the standard resistor.)
3. Connect the first ten resistors (in series) of a 1-kilohm-per-step SR 1010 to the STANDARD binding posts of the lead compensator.
4. Balance the bridge with the OFFSET dials. Do not adjust the RATIO dials.
5. Connect the first ten resistors of the 1-kilohm-per-step transfer standard in parallel with the shorting bars. Connect the parallel combination to the STANDARD binding posts of the lead compensator.
6. Connect 100-ohm resistor to be calibrated to the UNKNOWN binding posts of the lead compensator.
7. Balance the bridge with the RATIO dials. The indication of the RATIO dials is the ratio of the 100-ohm resistor to the actual value of 100 ohms as transferred from the primary standard.

#### 4.1.4 Transfer From 10 kilohms to 10 Ohms

1. Connect the 10-kilohm primary standard resistor (ESI Model SR 104 is recommended) to the UNKNOWN binding posts of the lead compensator. Use a four-terminal connection to the resistor and connect at least one GRD terminal on the standard resistor to a GRD terminal on the bridge.
2. Set RATIO controls of the ratio set to the calibrated resistance of the standard. Be sure to correct this setting for temperature. (ESI Model SR 104 contains an internal resistance temperature sensor which changes by 0.01% per degree Celsius. A calibration curve is included with the standard resistor.)
3. Connect ten resistors of a 1-kilohm-per-step SR 1010 in series to the STANDARD binding posts of the lead compensator. (This resistance is used only as a tare. Any highly stable 10-kilohm resistor can be used instead of the transfer standard.)
4. Balance the bridge with the OFFSET DIALS. Do not adjust the RATIO dials.



5. Connect the tenth resistor (R10) of the 10-kilohm-per-step SR 1010 to the UNKNOWN binding posts of the lead compensator.
6. Balance the bridge with the RATIO dials. Do not adjust the OFFSET dials. Record the reading of the RATIO dials as d (10).
7. Connect the 10-kilohm SR 1010 in series-parallel (paragraph 2.2.3) and connect the transfer standard to the UNKNOWN binding posts of the lead compensator.
8. Balance the bridge with the RATIO dials. Do not adjust the OFFSET dials. Record the setting of the RATIO dials as D (9).
9. Set the RATIO dials to the calculated setting:

$$\frac{d(10) + 9D(9)}{10}$$

10. Connect the first ten resistors of the 10-kilohm SR 1010 in parallel with the shorting bars. Connect the parallel combination to the UNKNOWN binding posts of the lead compensator.
11. Connect the first ten resistors of a 100-ohm-per-step SR 1010 in series to the STANDARD binding posts of the lead compensator.
12. Balance the bridge with the OFFSET dials. Do not adjust the RATIO dials.
13. Connect the first ten resistors of the 100-ohm SR 1010 in parallel with the shorting bars. Plus a Model PC 101 Parallel Compensating Network into the binding posts of the SR 1010.
14. Connect the binding posts on the Compensating Network to the outer STANDARD binding posts of the lead compensator (terminals 1 and 4, labeled GEN and YOKE) and the shorting bars to the inner STANDARD binding posts (terminals 2 and 3).
15. Connect 10-ohm resistor to be calibrated to the UNKNOWN binding posts of the lead compensator.
16. Balance the bridge with the RATIO dials. The indication of the RATIO dials is the ratio of the 10-ohm resistor to the actual value of 10 ohms as transferred from the primary standard.

#### 4.1.5 Transfer From 10 Kilohms to 1 Ohm

1. Connect the 10-kilohm primary standard resistor (ESI Model SR 104 recommended) to the UNKNOWN binding posts of the lead compensator. Use a four-terminal connection to the resistor and connect at least one GRD terminal on the standard resistor to one GRD terminal on the bridge.
2. Set RATIO dials of the ratio set to the calibrated resistance of the standard. Be sure to correct this setting for temperature. (ESI Model SR 104 contains an internal resistance temperature sensor which changes by 0.01% per degree Celsius. A calibration curve is included with the standard resistor.)

3. Connect a 10-kilohm tare resistor to the STANDARD terminals of the lead compensator. Use a 100-kilohm-per-step SR 1010 connected in parallel, a 10-kilohm-per-step SR 1010 connected in series-parallel, or some other highly stable 10-kilohm resistance. (Do not use the 1-kilohm-per-step SR 1010 unless you have two of them. One is required later.)
4. Balance the dials with the OFFSET dials. Do not adjust the RATIO dials.
5. Connect the first ten resistors in series of the 1-kilohm SR 1010 to the UNKNOWN binding posts of the lead compensator.
6. Balance the bridge with the RATIO dials. Do not adjust the OFFSET dials.
7. Connect the first ten resistors of the 1-kilohm SR 1010 in parallel with the shorting bars. Connect the parallel combination to the UNKNOWN binding posts of the lead compensator.
8. Connect the first ten resistors of a 10-ohm-per-step SR 1010/LTC in series to the STANDARD binding posts of the lead compensator.
9. Balance the bridge with the OFFSET dials. Do not adjust the RATIO dials.
10. Connect the first ten resistors of the 10-ohm-per-step SR 1010/LTC in parallel with the shorting bars. Plug a Model PC 101 Parallel Compensating Network into the binding posts of the SR 1010/LTC.
11. Connect the binding posts on the Compensating Network to the outer STANDARD binding posts of the lead compensator (terminals 1 and 4, labeled GEN and YOKE) and the shorting bars to the inner STANDARD binding posts (terminals 2 and 3).
12. Connect the 1-ohm resistor to be calibrated to the UNKNOWN binding posts of the lead compensator.
13. Balance the dials with the RATIO dials. The indication of the RATIO dials is the ratio of the 1-ohm resistor to the actual value of 1 ohm as transferred from the primary standard.

## 4.2 DETAILED TRANSFER TECHNIQUE WITH MODEL 242B RESISTANCE MEASUREMENT SYSTEM

*NOTE: A more accurate, trimmable version, the Model 242D, is also available. Its appearance and operation is similar to the Model 242B.*

### 4.2.1 System Description

ESI Model 242B Resistance Measuring System consists of the Model 240 Kelvin Ratio Bridge, the Model RS 925A Decade Resistance Standard, and the Model 801 DC Generator-Detector. The value of the resistor is read as the product of the decade reading and the multiplier reading (a power of 10). A deviation dial is provided for reading the difference between the actual ratio and the nominal ratio of the standard and unknown resistors.

### 4.2.2 Equipment Required

1. Model 242B Resistance Measuring System with KELVIN KLIPS<sup>®</sup> Four-Terminal Clips.
2. 100-ohm/step SR 1010 with Shorting Bars and PC 101 Parallel and SPC 102 Series-Parallel Compensation Networks.
3. 10-ohm Calibrated Standard Resistor (Value chosen as an example).
4. 100-ohm and 1-kilohm SR 1 Standard Resistors to be calibrated.
5. A black and a white 18-inch plug lead.
6. A data sheet as shown below.

## RESISTANCE TRANSFER DATA SHEET

10-ohm Standard	Certified Value	10 ohms _____ ppm
SR 1010 100 ohms/step	PARALLEL Calibrated Value ( $\Delta_{AV}$ )	10 ohms _____ ppm
SR 1010 100 ohms/step	R10: Series-Parallel Deviation ( $\Delta_D$ )	100 ohms _____ ppm
SR 1010 100 ohms/step	SERIES-PARALLEL Calibration $\Delta_{SP}$ _____ = $\left( \Delta_{AV}$ _____ + $\frac{\Delta_D}{10}$ _____ )	
SR 1 100 ohms	CALIBRATED VALUE	100 ohms _____ ppm
SR 1 1000 ohms	CALIBRATED VALUE	1000 ohms _____ ppm

### 4.2.3 Detailed Procedure

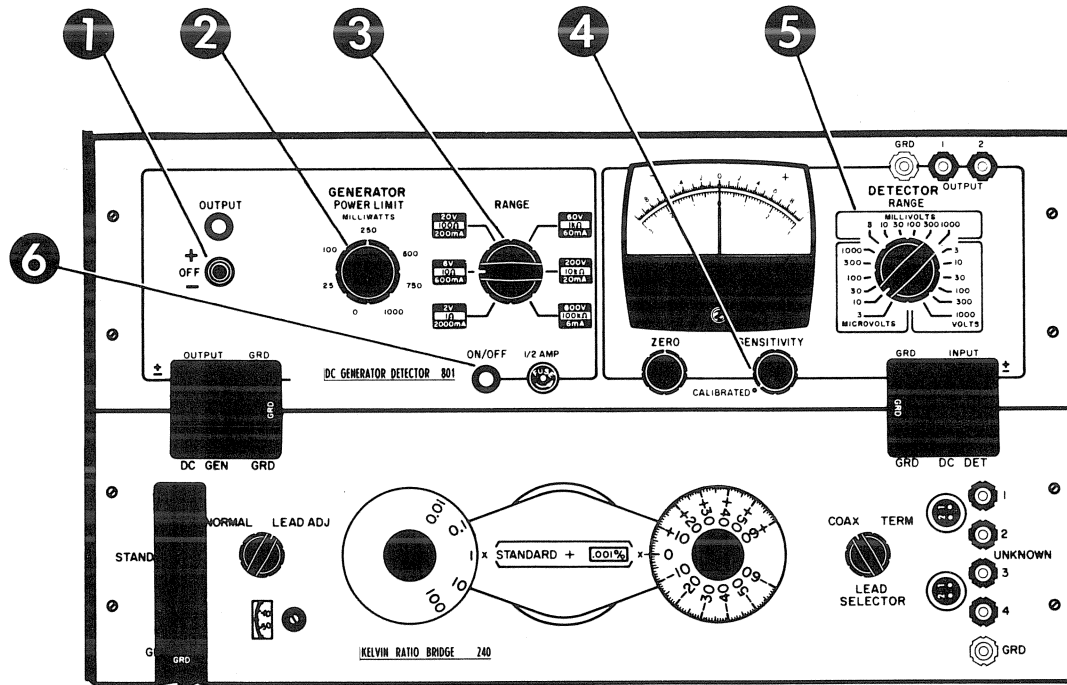

Figure 4-2.

#### A. 242B GENERATOR-DETECTOR DIAL SETTINGS

- (1) OUTPUT switch, set to OFF.
- (2) GENERATOR POWER, set to 250 MILLIWATTS.
- (3) GENERATOR RANGE switch, set to 10 ohms.
- (4) DETECTOR SENSITIVITY control, turn full counterclockwise.
- (5) DETECTOR RANGE switch, set to 10 MICROVOLTS.
- (6) Press ON/OFF pushbutton.

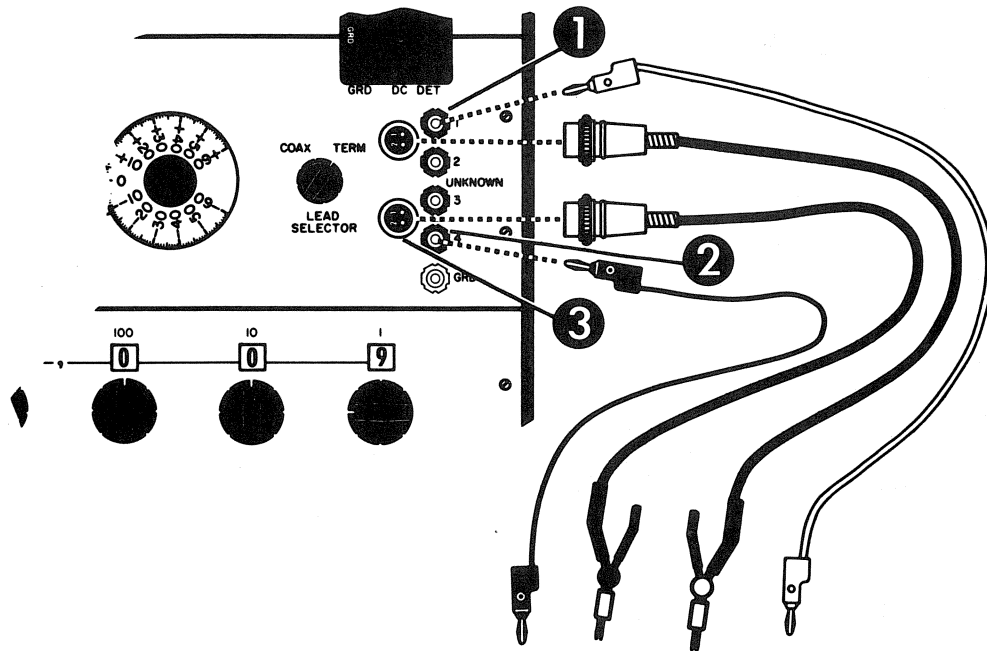

Figure 4-3.

#### B. 242B LEAD CONNECTIONS

- (1) White 18-inch plug lead, connect one end to 242B Bridge UNKNOWN terminal 1.
- (2) Black 18-inch plug lead, connect one end to bridge UNKNOWN terminal 4.
- (3) The two KELVIN KLIPS shielded coax leads are already attached to the 242B Bridge just to the left of UNKNOWN terminals 1 and 4. Examine the clip ends of the lead. Make sure the upper clip has a white center and the lower clip a black center.

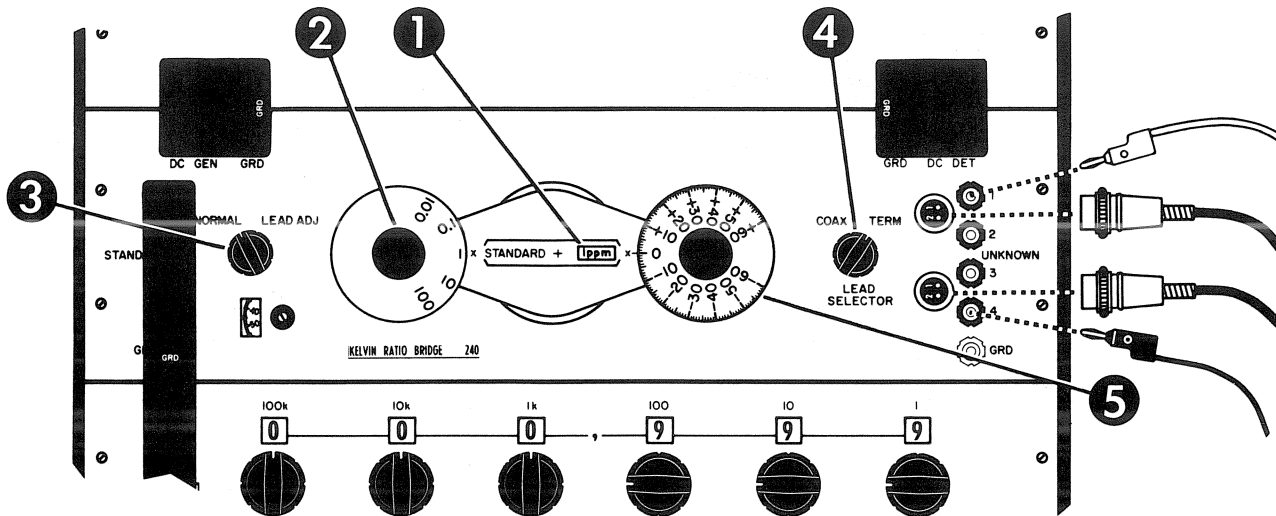

Figure 4-4.

### C. 242B BRIDGE DIAL SETTINGS

- (1) Directly in the center of the bridge is the DEVIATION RANGE dial. Set this dial to 1 ppm. The 1 ppm will appear in the small window on the right side of the dial mask.
- (2) To the left of this dial is the STANDARD MULTIPLIER dial. Set this dial to 1.
- (3) LEAD ADJUST switch, set to NORMAL.
- (4) LEAD SELECTOR switch, set to TERMinal.
- (5) Pick up the 10-ohm standard resistor and find its certified value. Subtract the nominal value (10 ohms in this case) from the certified value. Divide the result by the nominal value (10) and by one million. This is the certified deviation in ppm. This deviation is plus if the certified value is above the nominal value, minus if it is below. Set the certified deviation on the bridge DEVIATION dial.
- (6) Record the certified deviation on the data sheet.

10-ohm Standard Certified Value

10 ohms \_\_\_\_\_ ppm

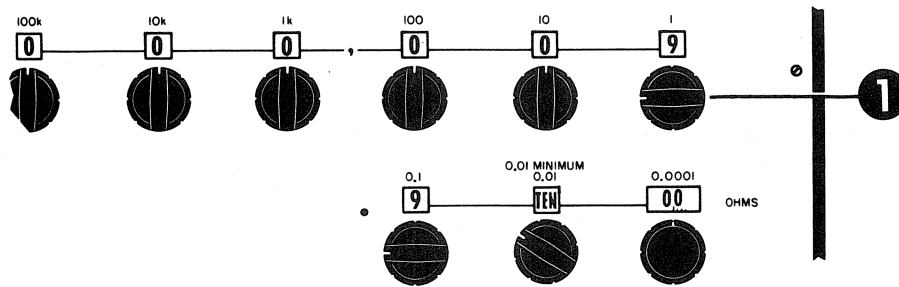

Figure 4-5.

#### D. 242B RESISTANCE STANDARD DIAL SETTING

- (1) RESISTANCE STANDARD dials, set to 9 .9 TEN 00 for ten ohms. Check that all other dials on the RESISTANCE STANDARD are set to 0.

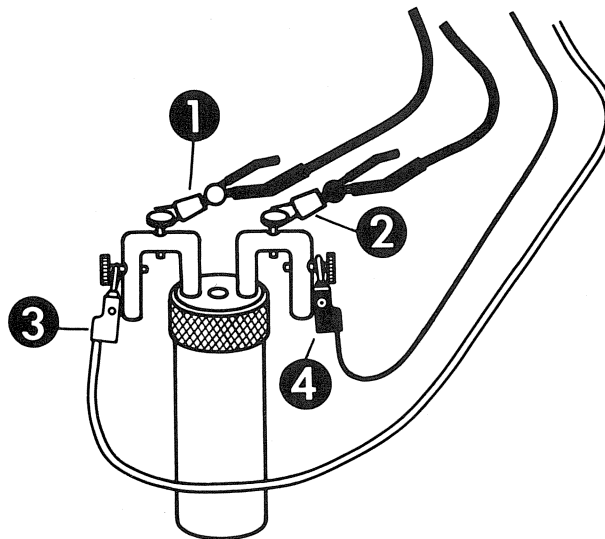

Figure 4-6.

#### E. 10-OHM STANDARD RESISTOR CONNECTION

- (1) Pick up the  $10\Omega$  standard resistor and connect the white KELVIN KLIP to the inner screw on one arm.
- (2) Connect the black KELVIN KLIP to the inner screw on the other arm.
- (3) Connect the white plug lead to outer screw on the first arm.
- (4) Connect the black plug lead to outer screw on second arm.

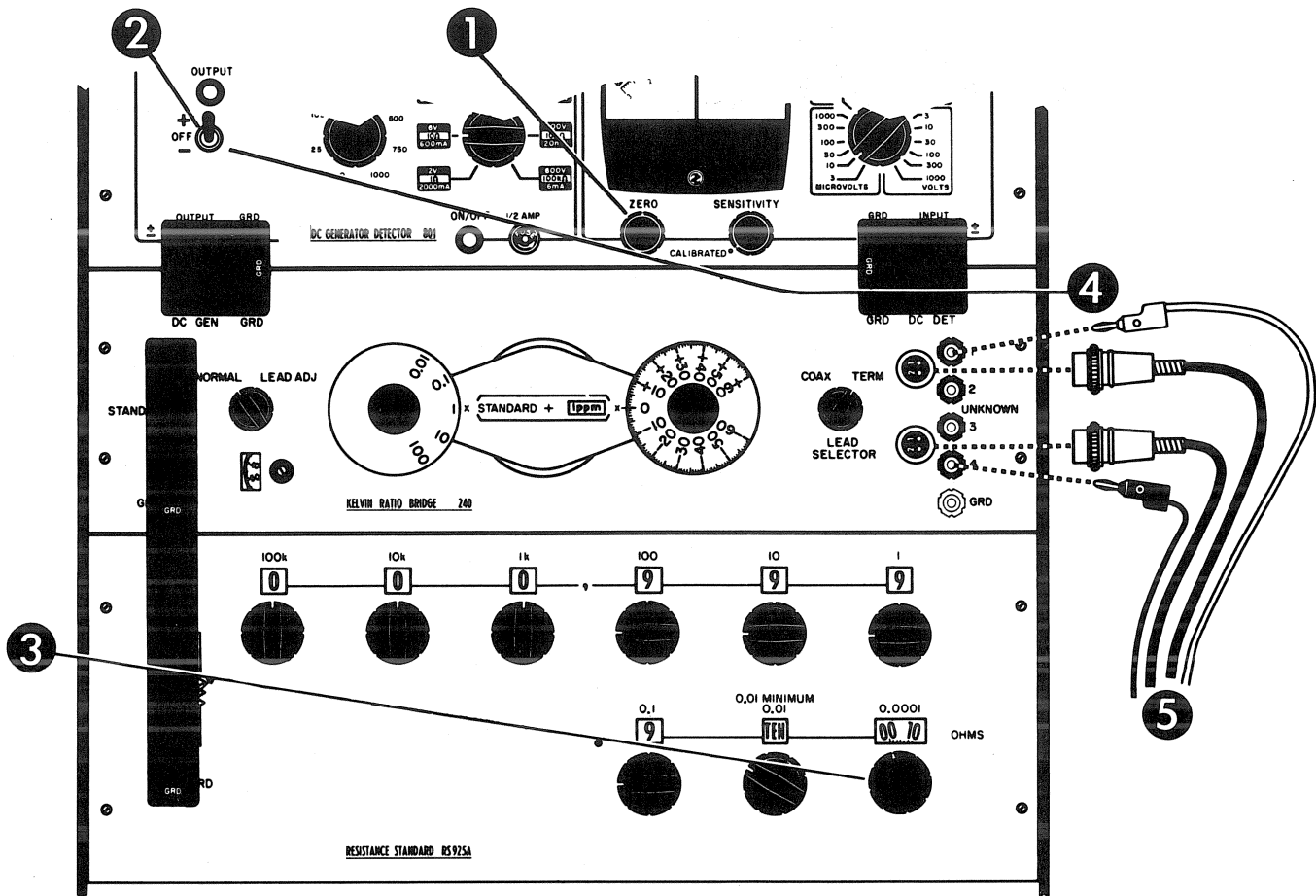

Figure 4-7.

F. 242B SYSTEM CALIBRATION AT 10 OHMS

- (1) 242B ZERO control, adjust for meter zero.
- (2) OUTPUT switch, set to plus position.
- (3) Adjust the RESISTANCE STANDARD starting with the x0.0001 dial for a meter null. (If the meter pointer is off scale, change the DETECTOR RANGE to reduce sensitivity. Return to 10 MICROVOLT position for final null balance.) The 242B System is now calibrated for 10Ω in terms of the 10 ohm standard resistor.
- (4) OUTPUT switch OFF.
- (5) Remove all leads from the SR1.



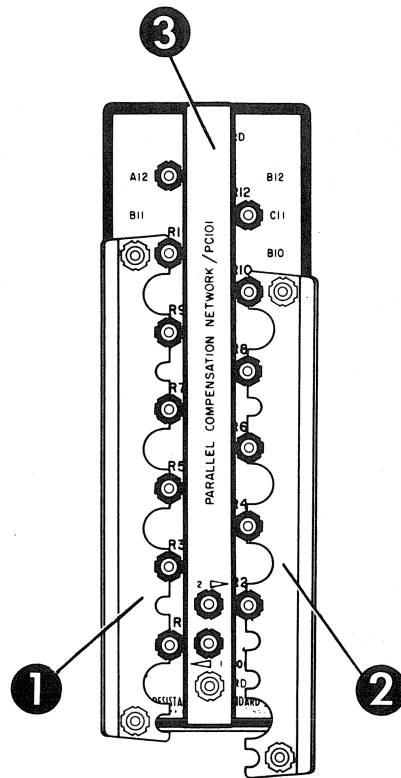

Figure 4-8.

#### G. 100-OHM/STEP SR 1010 CALIBRATION AT 10 OHMS

##### Shorting Bar and Network Connections:

- (1) Pick up the SR 1010 100 $\Omega$ /step box and place it so that the Calibration Card end faces you. Hold a gold-plated Shorting Bar beside the row of binding posts on your left so that its end binding post is opposite A10. Connect the Shorting Bar at A10, A8, A6, A4, A2, and A0. Tighten these binding posts.
- (2) Hold the other Shorting Bar on your right so its end binding post is opposite C9. Connect the Shorting Bar at C9, C7, C5, C3, C1. Tighten these binding posts.
- (3) Pick up the PC 101 Network. Place the gold GRD Terminal on the network above the gold GRD terminal at the Calibration Card end of the SR1010. Connect the PC 101 Network to the SR1010 center row of binding posts.

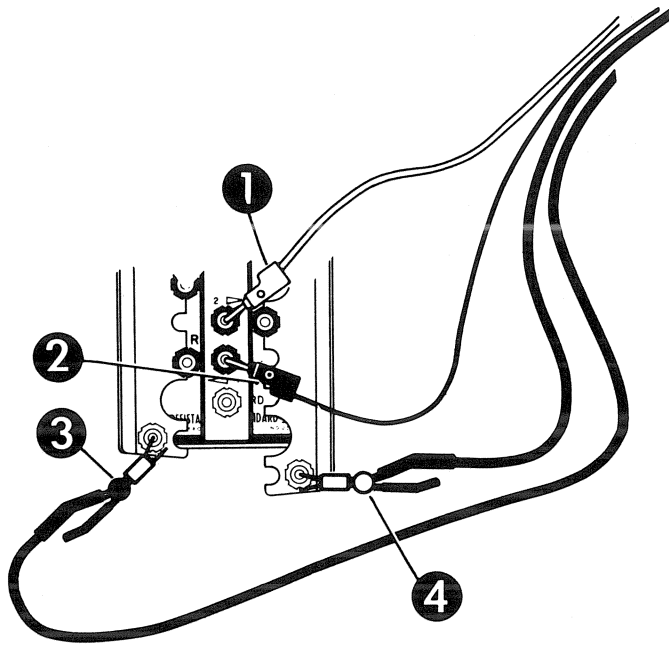

Figure 4-9.

#### H. 242B LEAD CONNECTIONS TO THE SR 1010

- (1) Connect the white plug lead to the PC 101 Network terminal 2.
- (2) Connect the black plug lead to the PC 101 Network terminal 1.
- (3) Connect the black KELVIN KLIP to the left-hand Shorting Bar binding post. Place one jaw inside and one outside of the binding post.
- (4) Connect the white KELVIN KLIP to the right-hand Shorting Bar binding post.

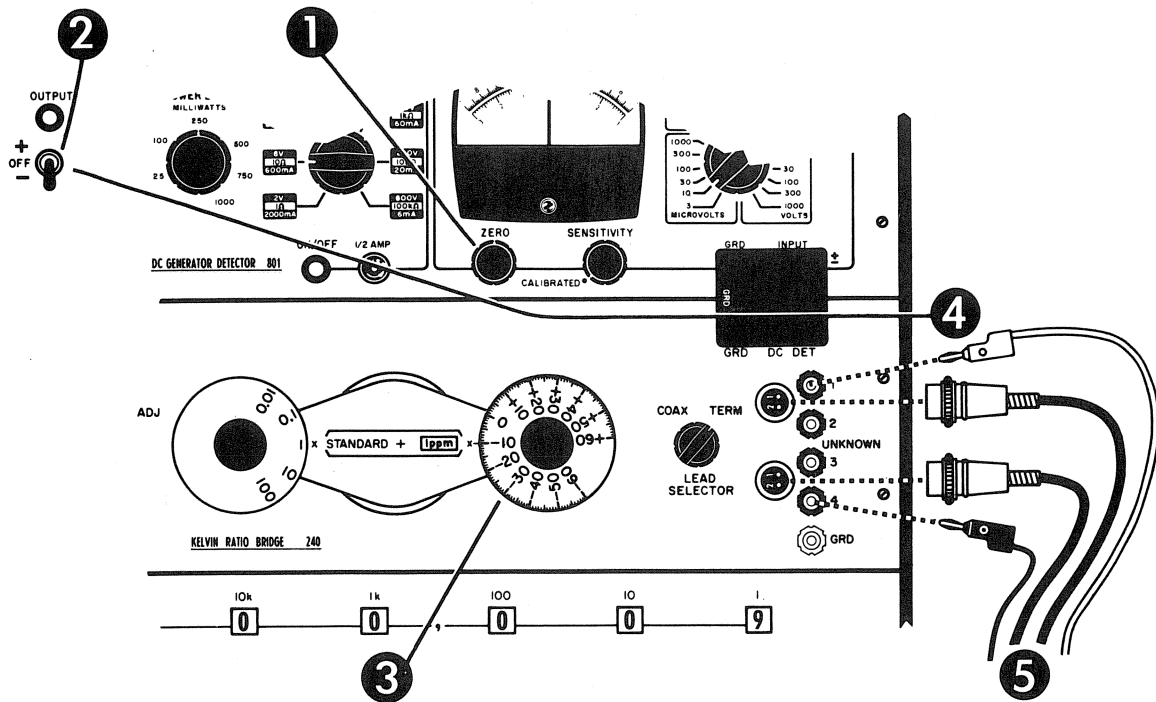

Figure 4-10.

### I. SR 1010 DEVIATION MEASUREMENT

- (1) 242B ZERO Control, adjust for meter zero.
- (2) OUTPUT switch, set to minus position.
- (3) Rotate the bridge DEVIATION dial for a meter null.
- (4) OUTPUT switch OFF; record the DEVIATION dial reading on the data sheet.\* This is  $\Delta_{AV}$ ; the deviation of ten 100-ohm resistors in parallel from the calibrated 10-ohm value of the 242B System.
- (5) Remove all leads from the SR 1010 Shorting Bars and Network.

\* SR 1010 100 ohms/step PARALLEL Calibrated Value ( $\Delta_{AV}$ ) 10 ohms \_\_\_\_\_ ppm

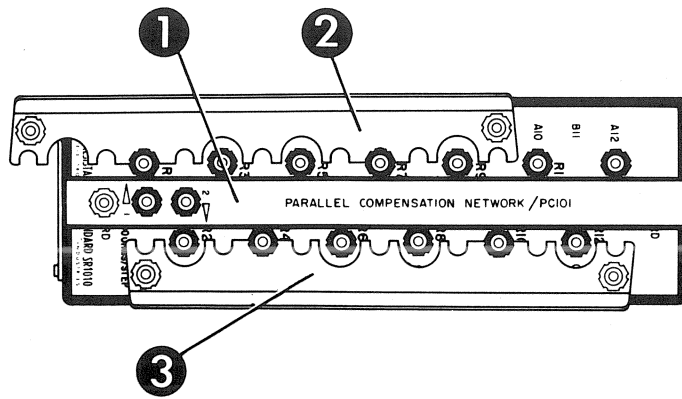

Figure 4-11.

#### J. 242B CALIBRATION AT 100 OHMS

##### Shorting Bar Connection:

- (1) Remove the PC 101 Network from the SR 1010 by grasping both ends of the Network and pulling straight up to avoid bending the banana plug.
- (2) Loosen the left-hand Shorting Bar. With the end binding post opposite B9, connect it at A0 and A6. Tighten these binding posts.
- (3) Loosen the right-hand Shorting Bar. With the end Shorting Bar binding posts held opposite B0 and B12, connect at C3 and C9. Tighten these binding posts.

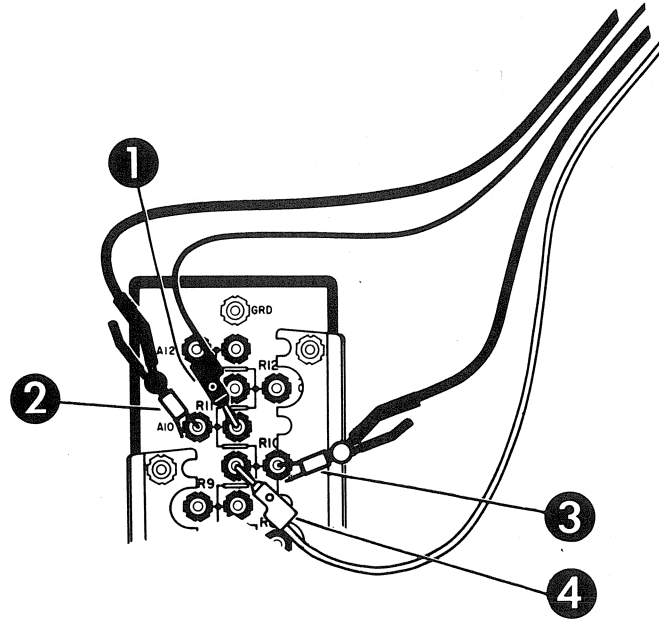

Figure 4-12.

#### K. SR 1010 LEAD CONNECTION

- (1) Connect the black plug lead to SR 1010 terminal B10.
- (2) Pick up the black KELVIN KLIP. Observe that one jaw is directly connected to the coax cable. Connect the black KELVIN KLIP to terminal A10 so that this jaw is in contact with the interior surface of the binding posts.
- (3) Connect the white KELVIN KLIP to terminal C9 in the same way.
- (4) Connect the white plug lead to terminal B9.

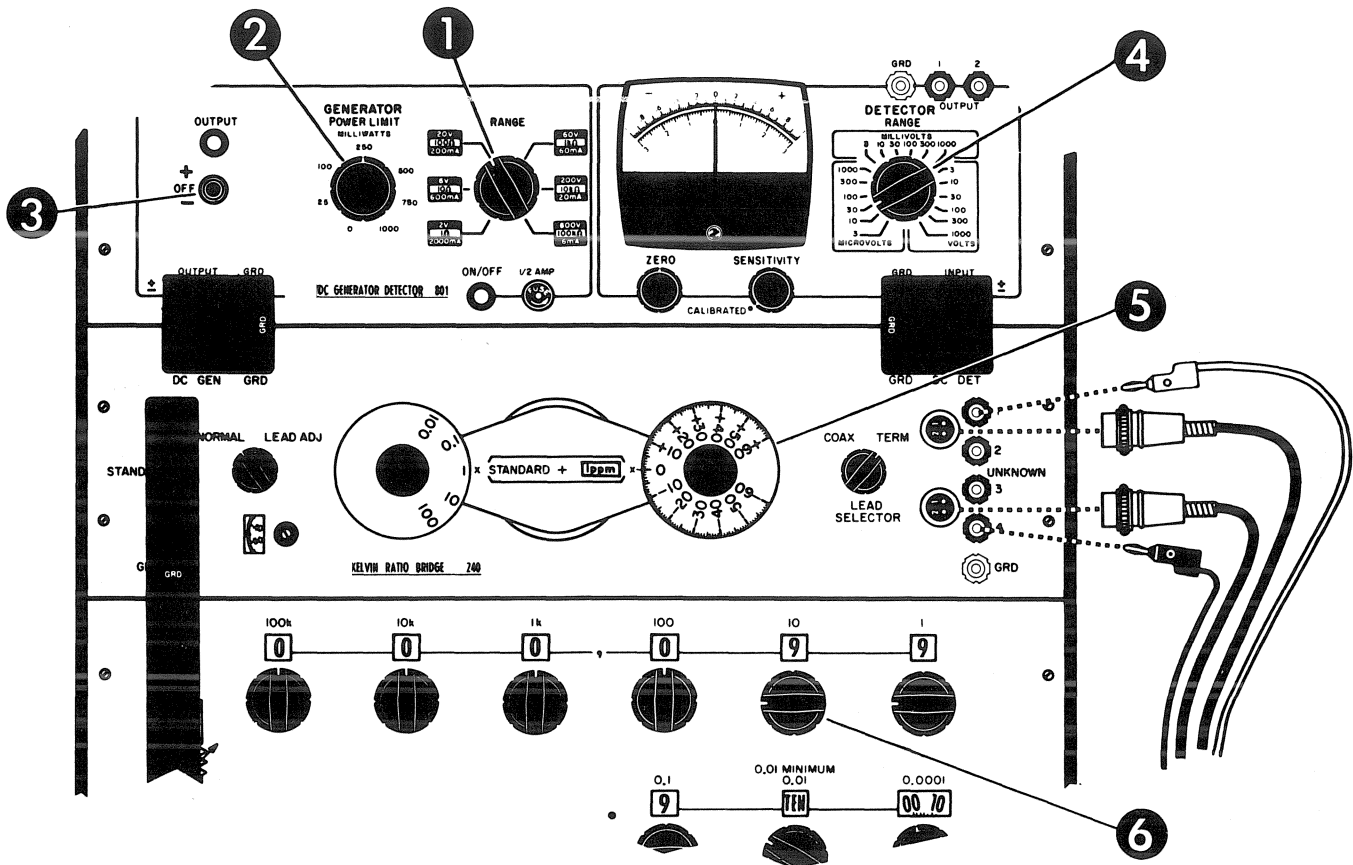

Figure 4-13.

L. 242B SYSTEM DIAL SETTINGS

- (1) GENERATOR RESISTANCE, set to  $100\Omega$ .
- (2) GENERATOR POWER, set to 250 MILLIWATTS.
- (3) OUTPUT switch, set to OFF.
- (4) DETECTOR RANGE switch, set to 30 MICROVOLTS.
- (5) Bridge DEVIATION dial, set to 0.
- (6) RESISTANCE STANDARD  $\times 10$  dial, rotate counter clockwise to 9.

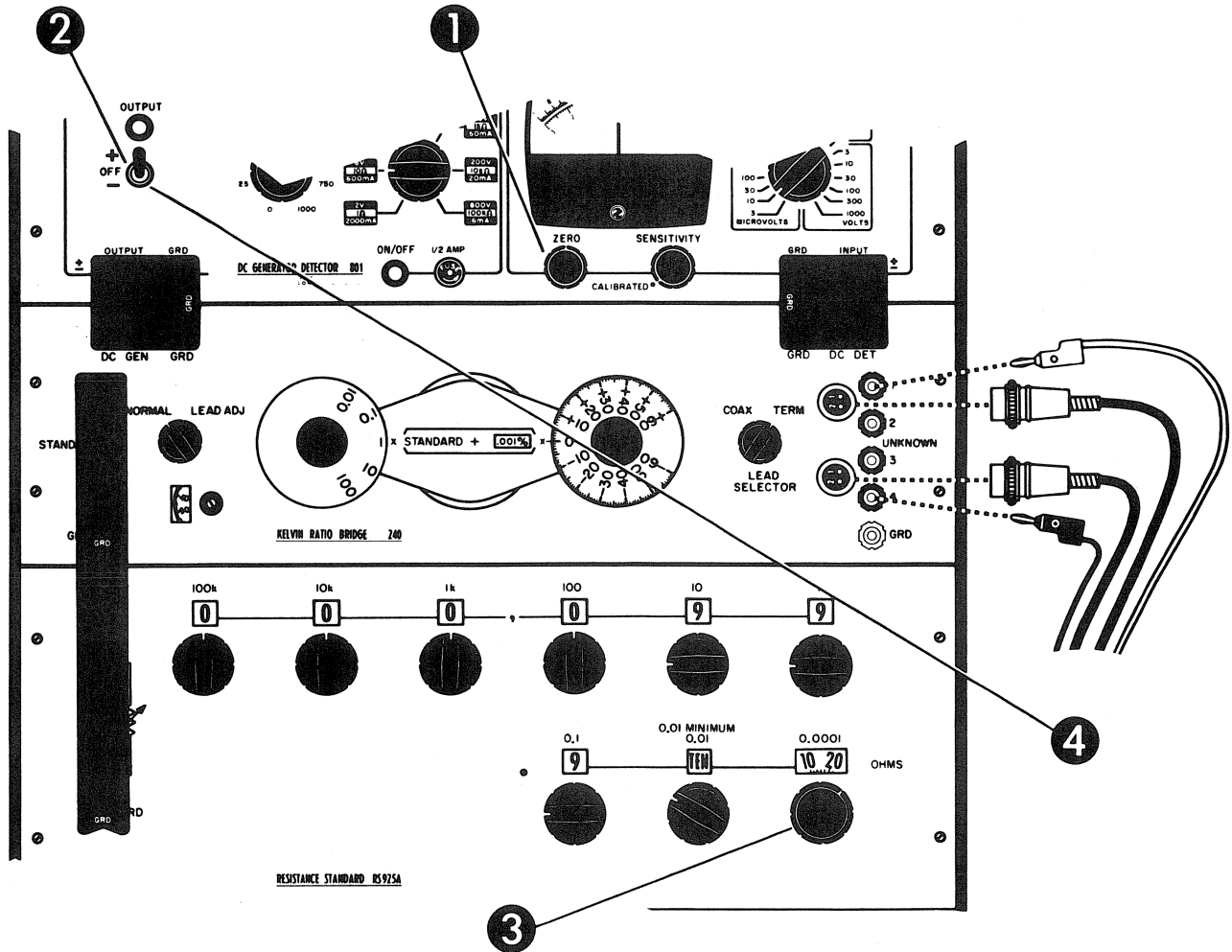

Figure 4-14.

M. 242B MEASUREMENT OF SR 1010 R10 RESISTOR

- (1) 242B ZERO control, adjust for meter zero.
- (2) OUTPUT switch, set to plus position.
- (3) Rotate RESISTANCE STANDARD dials for meter null.
- (4) OUTPUT switch OFF. Check meter zero. Repeat if necessary.

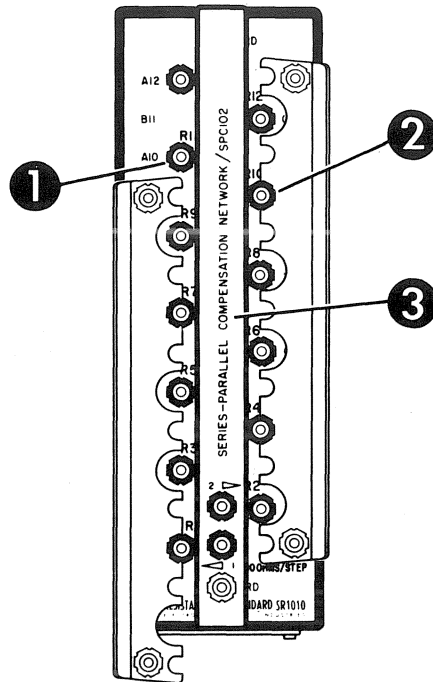

Figure 4-15.

#### N. SR1010 LEAD AND NETWORK CONNECTIONS

- (1) Remove the black and white KELVIN KLIPS from terminals A10 and C9.
- (2) Remove the black and white plug leads from terminals B10 and B9.
- (3) Pick up the SPC 102 Network. The GRD terminal on the Network will connect to the GRD terminal at the Calibration Card end of the SR 1010. Connect SPC 102 Network to center row of terminals on the SR 1010.



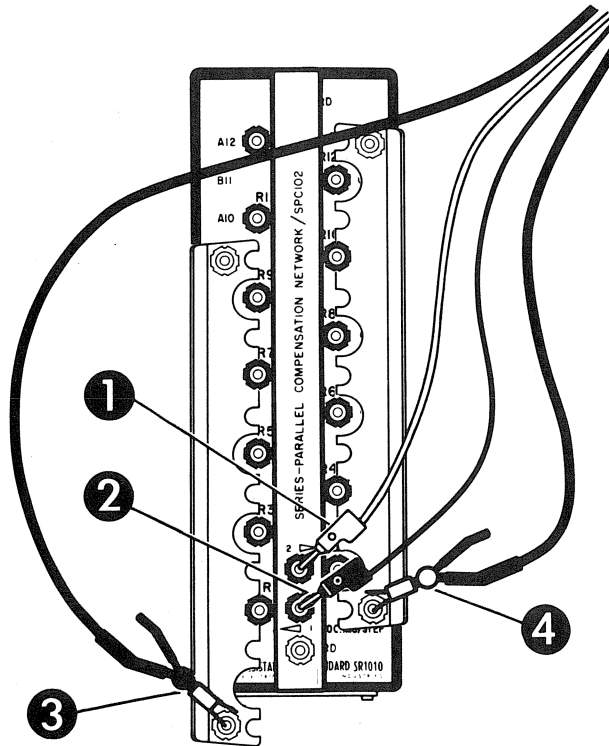

Figure 4-16.

O. SR1010 LEAD CONNECTIONS

- (1) Connect the white plug lead to the SPC 102 Network terminal 2.
- (2) Connect the black plug lead to the SPC 102 Network terminal 1.
- (3) Connect the black KELVIN KLIP to the left-hand Shorting Bar binding post.
- (4) Connect the white KELVIN KLIP to the right-hand Shorting Bar binding post.

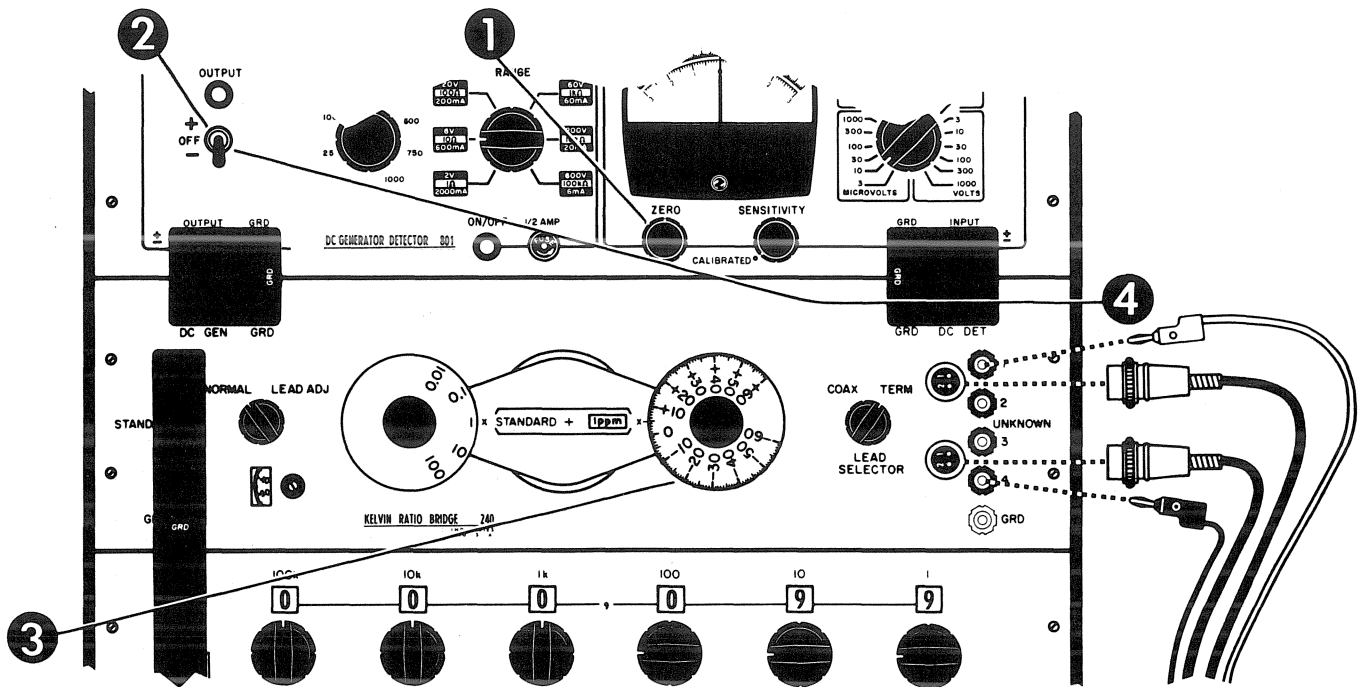

Figure 4-17.

P. SR 1010 SERIES-PARALLEL DEVIATION FROM R10

- (1) 242B ZERO Control, adjust for meter zero.
- (2) OUTPUT switch, set to minus position.
- (3) Rotate bridge DEVIATION dial for meter null.
- (4) OUTPUT switch OFF.

Record the Deviation reading on the Data Sheet\* as  $\Delta_D$ ; This is the deviation of the series-parallel combination of the nine 100-ohm resistors from R10.

Calculate  $\Delta_{sp}$  on the Data Sheet, using the printed equation.  $\Delta_{sp}$  is the deviation of the series-parallel connection from 10 times the nominal value of the 10-Ohm Standard relative to its certificate.

\* SR 1010 100 ohms/step R10: Series-Parallel Deviation ( $\Delta_D$ ) 100 ohms \_\_\_\_\_ ppm

SR 1010 100 ohms/step SERIES-PARALLEL Calibration  $\Delta_{SP}$  \_\_\_\_\_ =  $\left( \Delta_{AV}$  \_\_\_\_\_ +  $\frac{\Delta_D}{10}$  \_\_\_\_\_ )

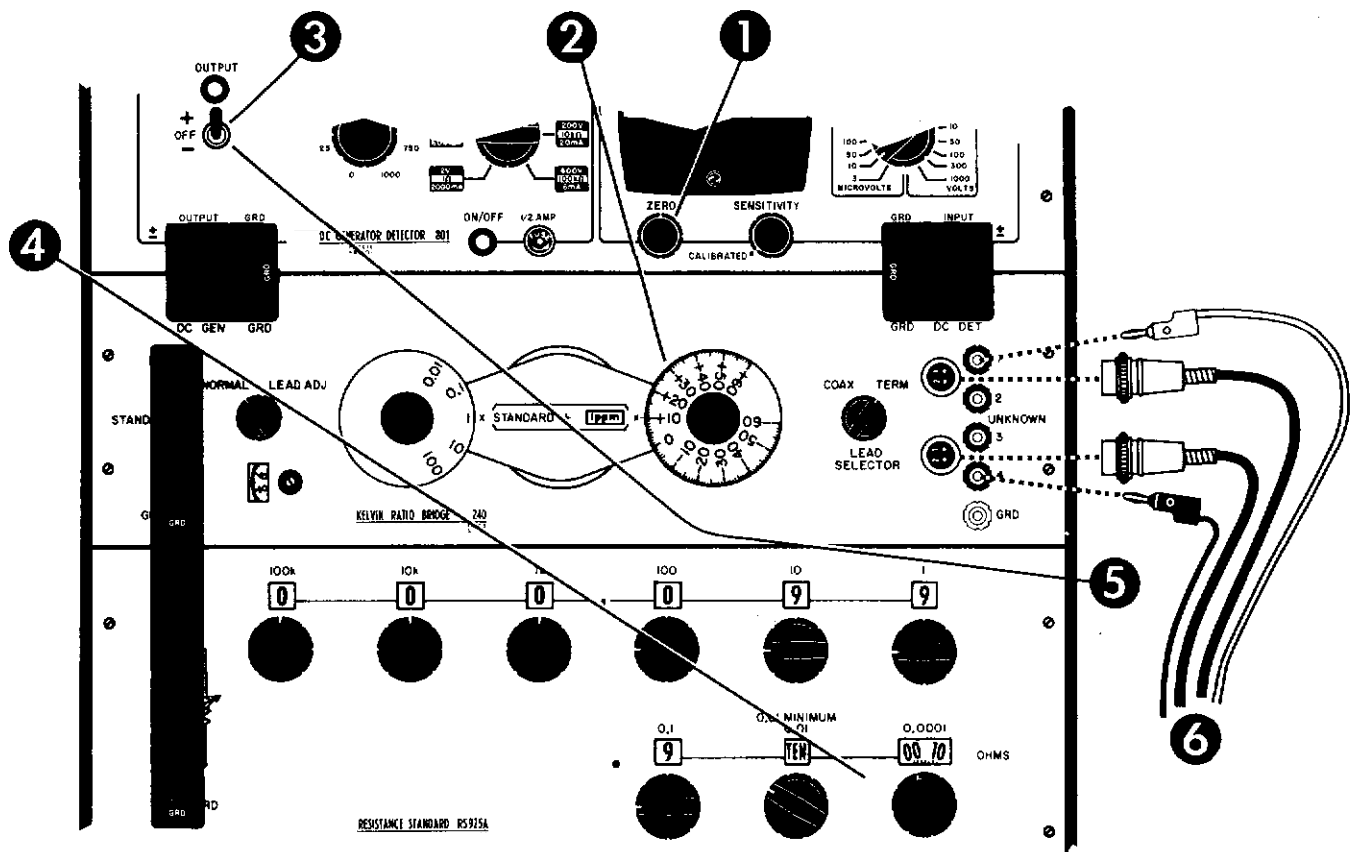

Figure 4-18.

Q. 242B BRIDGE CALIBRATION AT 100 OHMS

- (1) 242B ZERO control, adjust for meter zero.
- (2) Bridge DEVIATION dial, set to  $\Delta_{sp}$ .
- (3) OUTPUT switch, set to plus position.
- (4) Rotate RESISTANCE STANDARD dials for meter null.
- (5) OUTPUT switch OFF. The 242B Bridge is now calibrated to read 100 ohms relative to the 10-ohm standard certified accuracy.
- (6) Remove all leads from the SR1010. Remove the SPC 102 Resistance Network by grasping the ends of the Network and pulling straight up to avoid bending the banana plug. Remove the Shorting Bars. Fingertighten all loose binding posts on the SR1010.

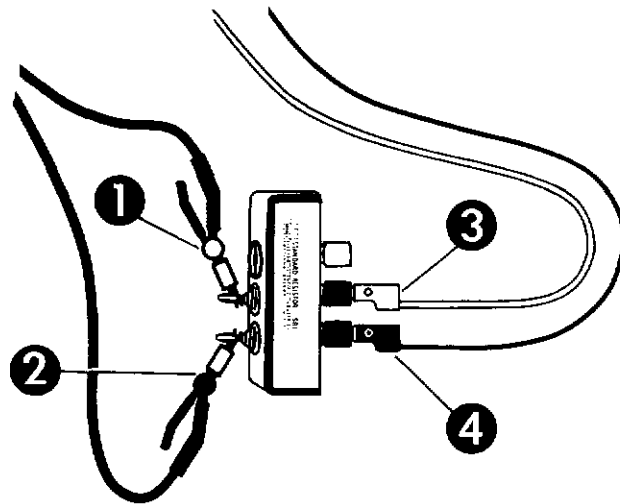

Figure 4-19.

#### R. 100-OHM SR1 CALIBRATION

##### 100-Ohm SR1 Lead Connections:

- (1) Pick up the 100-ohm SR 1 and connect the white KELVIN KLIP to the banana plug on the bottom of terminal 1.
- (2) Connect the black KELVIN KLIP to the banana plug on the bottom of terminal 2.
- (3) Connect the white plug lead to terminal 1.
- (4) Connect the black plug lead to terminal 2.

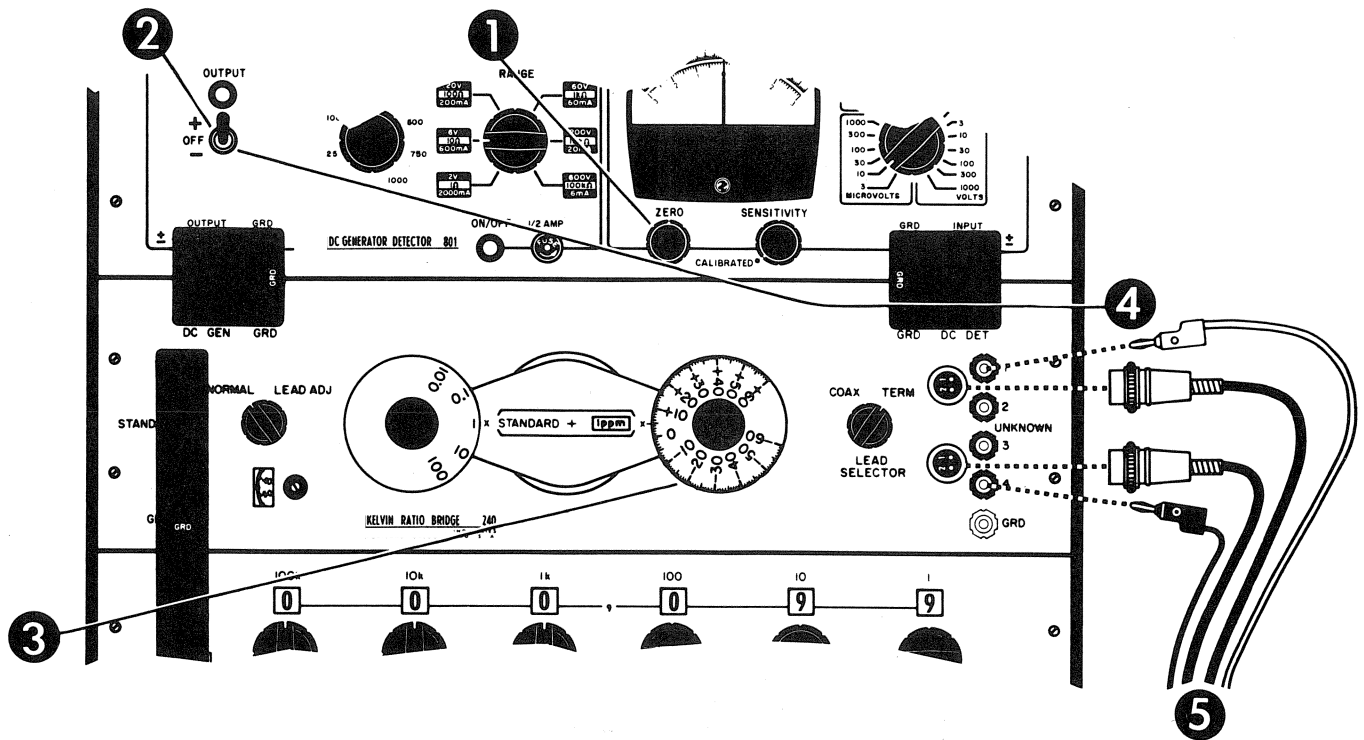

Figure 4-20.

S. 242B CALIBRATION OF 100-OHM SR 1

- (1) 242B ZERO control, adjust for meter zero.
- (2) OUTPUT switch, set to minus position.
- (3) Rotate bridge DEVIATION dial for meter null.
- (4) OUTPUT switch OFF.

Record the DEVIATION dial reading on the Data Sheet\*. This is the deviation of the 100-Ohm SR 1 Standard Resistor from its nominal value relative to the certified deviation of the 10-Ohm Standard within the accuracy of the transfer measurement.

- (5) Remove all leads from the 100-Ohm SR 1.

\*SR 1    100 ohms    CALIBRATED VALUE    100 ohms \_\_\_\_\_ ppm

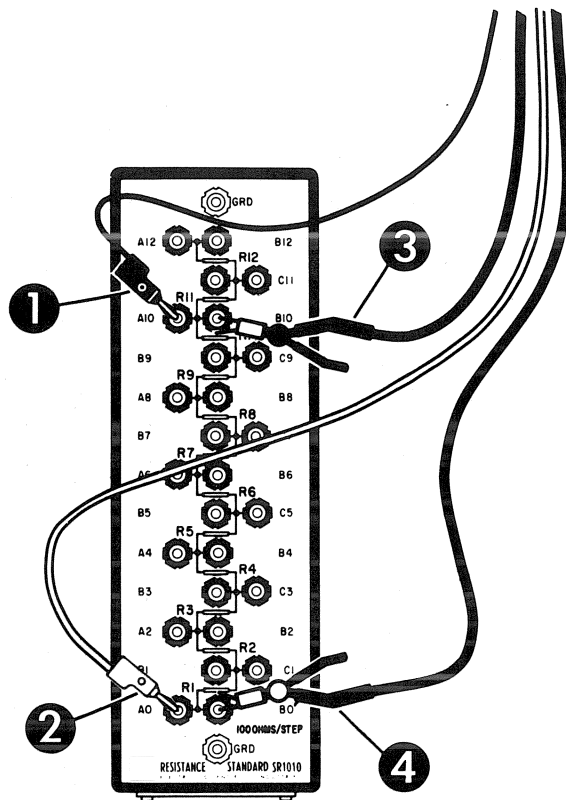

Figure 4-21.

#### T. 242B BRIDGE CALIBRATION AT 1 KILOHM

##### SR 1010 Lead Connections:

- (1) Connect the black plug lead to terminal A10.
- (2) Connect the white plug lead to terminal A0.
- (3) Connect the black KELVIN KLIP to terminal B10.
- (4) Connect the white KELVIN KLIP to terminal B0. Remember, KELVIN KLIPS are connected to the SR 1010 terminal with the jaw, to which the coax cable is attached, in contact with the interior surface of the binding post.

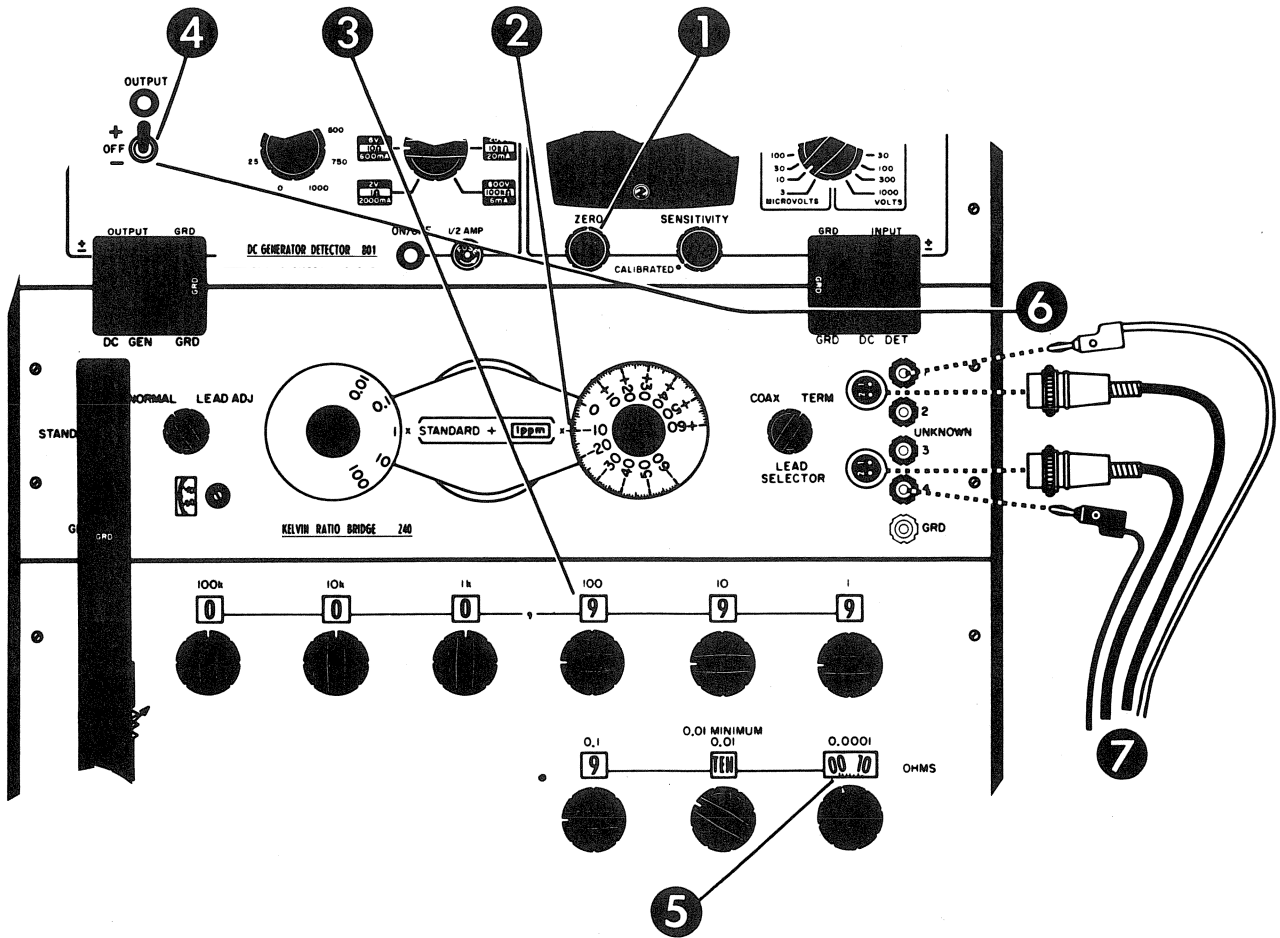

Figure 4-22.

U. 242B BRIDGE CALIBRATION AT 1 KILOHM

- (1) 242B ZERO control, adjust for meter zero.
- (2) Bridge DEVIATION dial, set to  $\Delta_{AV}$ .
- (3) RESISTANCE STANDARD  $\times 100$  dial, rotate counter-clockwise to 9.
- (4) OUTPUT switch, set to plus position.
- (5) RESISTANCE STANDARD dials, rotate for meter null.
- (6) OUTPUT switch OFF. The 242B Bridge is now calibrated to measure a 1-kilohm resistance.
- (7) Remove all leads from the SR 1010.

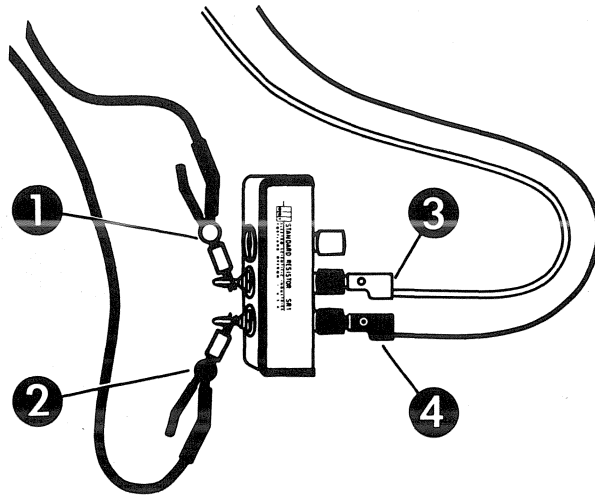

Figure 4-23.

## V. CALIBRATION OF 1-KILOHM SR1 STANDARD RESISTOR

### 1-Kilohm SR1 Lead Connections:

- (1) Pick up the 1-Kilohm SR1 and connect the white KELVIN KLIP to the banana plug on the bottom of terminal 1.
- (2) Connect the black KELVIN KLIP to the banana plug on the bottom of terminal 2.
- (3) Connect the white plug lead to terminal 1.
- (4) Connect the black plug lead to terminal 2.



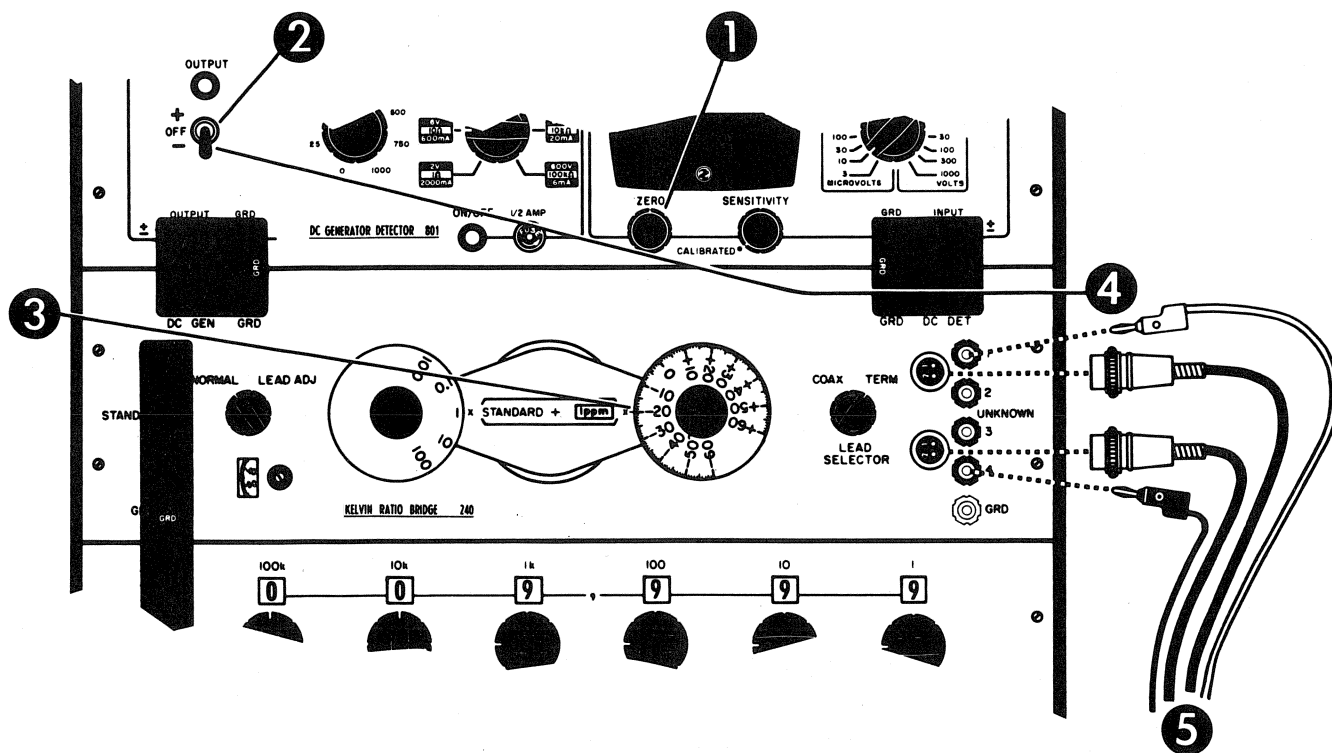

Figure 4-24.

W. 242B CALIBRATION OF 1-KILOHM SR 1

- (1) 242B ZERO Control, adjust for meter zero.
- (2) OUTPUT switch, set to minus position.
- (3) Bridge DEVIATION dial, rotate for meter null.
- (4) OUTPUT switch OFF.

Record\* the DEVIATION dial reading. This is the deviation of the 1-Kilohm SR1 Standard Resistor from its nominal value relative to the Certified Deviation of the 10-Ohm Standard within the accuracy of the transfer measurement.

- (5) Remove all leads from the 1-Kilohm SR 1.

\*SR 1 1000 ohms CALIBRATED VALUE 1000 ohms \_\_\_\_\_ ppm

## RESISTANCE TRANSFER DATA SHEET

10-ohm	Standard	Certified Value	10 ohms _____ ppm
SR 1010	100 ohms/step	PARALLEL Calibrated Value ( $\Delta_{AV}$ )	10 ohms _____ ppm
SR 1010	100 ohms/step	R10: Series-Parallel Deviation ( $\Delta_D$ )	100 ohms _____ ppm
SR 1010	100 ohms/step	SERIES-PARALLEL Calibration	$\Delta_{SP} \text{_____} = \left( \Delta_{AV} \text{_____} + \frac{\Delta_D}{10} \text{_____} \right)$
SR 1	100 ohms	CALIBRATED VALUE	100 ohms _____ ppm
SR 1	1000 ohms	CALIBRATED VALUE	1000 ohms _____ ppm

## SECTION V

### PARTS LIST

Manufacturer of the part is given in a code number according to the Federal Supply Code for Manufacturers; see list of manufacturers below. Parts recommended as spares to sustain operation in isolated locations are indicated in the recommended spare parts column.

Parts manufactured by Electro Scientific Industries must be ordered from the factory. When ordering parts from the factory include the following information:

Model and serial number of the instrument  
Electro Scientific Industries part number  
Circuit reference designator  
Description of part

#### CODE LIST OF MANUFACTURERS

11702 SYRACUSE RUBBER PRODUCTS COMPANY  
Syracuse, New York

11837 ELECTRO SCIENTIFIC INDUSTRIES  
Portland, Oregon

Description	Mfr	ESI Part No.	Qty Used	Recm SP
Cap, Binding Post, Metal	11837	1172	2	2
Cap, Binding Post, Insulated	11837	1170	26	12
Bumper, Rubber Mfr PN M-266	11702	8739	4	2
Holder, Card	11837	8535	1	1
Card, Calibration	11837	8536	1	5

